

# FORSYTH BARR

FORSYTH BARR BUILDING STAIRS  
SITE EXAMINATION AND MATERIALS TESTS  
FOR DEPARTMENT OF BUILDING AND HOUSING  
22ND SEPTEMBER 2011



REPORT PREPARED FOR:  
**DEPARTMENT OF BUILDING AND HOUSING**

---

REPORT PREPARED FOR:

**MIKE STANNARD**

Chief Engineer, Department of Building and Housing

REPORT PREPARED BY:

**DR CLARK HYLAND**

PhD, BE(Civil), BCom, CWE-NZIW, CPEng

Hyland Fatigue + Earthquake Engineering  
PO Box 97282, Manukau, AUCKLAND 2241

Phone: (09) 262 0203

Mobile: 021 348 352

Email: [clark@fatigueandfracture.com](mailto:clark@fatigueandfracture.com)

[www.fatigueandfracture.com](http://www.fatigueandfracture.com)

Report Issue Date: 22 September 2011

Report Issue Status: Final

**Limitations and Applicability of Report:**

This report has been prepared solely on the basis of instructions from the Department of Building and Housing ("DBH") and in accordance with the guidelines and scope set by DBH. No liability is accepted by Hyland Consultants Limited or agents of Hyland Consultants Limited in respect to its use for any other purpose or by any other person or organisation.

This disclaimer shall apply notwithstanding that the report may be made available to other persons to fulfil a legal requirement.

This report has not been prepared for the purpose of determining liability or fault or blame.

Hyland Consultants Limited accepts no liability for use of this report other than for the purpose referred to above, nor does it accept liability for matters which fall outside the scope set by DBH.

Hyland Consultants Limited retains copyright of this report. This report may be reproduced and published but only in full and provided that it is not purported to be published under authority from Hyland Consultants Limited and that, in every case, acknowledgement is made of its source and that this disclaimer is incorporated in its publication.

Any opinions of Hyland Consultants Limited contained in this report are for information purposes only. Hyland Consultants Limited does not accept liability to any party, including DBH, for any statement contained in any opinion.

## FORSYTH BARR BUILDING STAIRS SITE EXAMINATION AND MATERIALS TESTS

**TABLE OF CONTENTS**

<b>Executive Summary</b> .....	<b>1</b>
Results of the Stairwell and Stair Remnants Examinations.....	1
Results of Materials Testing.....	5
Reinforcing Steel.....	5
Concrete.....	5
Seismic Gap Mortar.....	5
<b>Technical Summary</b> .....	<b>7</b>
<b>I. Introduction</b> .....	<b>11</b>
a. Objective.....	11
b. Scope.....	11
c. Background.....	11
<b>2. Stairwell Examination</b> .....	<b>13</b>
a. Level 9 Southwest Exit.....	14
i. Level 9 Southwest Exit L9 to L10 Stair Flight.....	14
ii. Level 9 Southwest Exit L9 to L8 Stair Flight.....	14
b. Level 12 Northeast Exit.....	15
i. Level 12 Northeast Exit L12 to L11 Stair Flight.....	15
ii. Level 12 Northeast Exit L12 to L13 Stair Flight.....	15
c. Level 15 Northeast Exit.....	16
i. Level 15 Northeast Exit L15 to L16 Stair Flight.....	16
ii. Level 15 Northeast Exit L15 to L14 Stair Flight.....	16
d. Level 15 Southwest Exit.....	18
i. Level 15 Southwest Exit L15 to L14 Stair Flight.....	18
ii. Level 15 Southwest Exit L15 to L16 Stair Flight.....	18
e. Level 16 Southwest Exit.....	19
i. Level 16 Southwest Exit L16 to L17 Stair Flight.....	19
ii. Level 16 Southwest Exit L16 to L15 Stair Flight.....	19
f. Level 16 Northeast Exit.....	20
i. Level 16 Northeast Exit L16 to L17 Stair Flight.....	20
ii. Level 16 Northeast Exit L16 to L15 Stair Flight.....	20
g. Level 17 Northeast Exit.....	21
i. Level 17 Northeast Exit L17 to L18 Stair Flight.....	21
ii. Level 17 Northeast Exit L17 to L16 Stair Flight.....	21
<b>3. Stair Remnants Examination</b> .....	<b>23</b>
a. Summary.....	23
b. Stairwell Access for Stair Remnant Retrieval.....	25
c. Upper Landing Reinforcing Fractures in Stairs.....	25
<b>4. Materials Properties</b> .....	<b>27</b>
a. Reinforcing Steel.....	27
b. Concrete Cores.....	27
c. Seismic Gap Mortar Strip Compressive Strength.....	28



## FORSYTH BARR BUILDING STAIRS SITE EXAMINATION AND MATERIALS TESTS

<b>5. Conclusions.....</b>	<b>29</b>
<b>6. References.....</b>	<b>31</b>
<b>Appendix A - Salvaged Stair Remnant Photos.....</b>	<b>33</b>
a. Unit 1.....	33
b. Unit 2.....	33
c. Unit 3.....	34
d. Unit 4.....	34
e. Unit 5.....	35
f. Unit 6.....	35
g. Unit 7.....	36
h. Unit 8.....	36
i. Unit 9.....	36
j. Unit 10.....	37
k. Unit 11.....	37
l. Unit 12.....	38
m. Unit 13.....	38
n. Unit 14.....	38
o. Unit 15.....	39
p. Unit 16.....	39
q. Unit 17.....	39
r. Unit 18.....	40
s. Other Stair Remnants.....	40
<b>Appendix B - Reinforcing Steel Test Results.....</b>	<b>41</b>
<b>Appendix C - Drilled Concrete Core Test Results.....</b>	<b>45</b>
<b>Appendix D – Stair Seismic Gap Mortar Test Results.....</b>	<b>47</b>
<b>Appendix E – Layout Drawings.....</b>	<b>51</b>



## EXECUTIVE SUMMARY

The concrete stair flights running downwards from the Level 15 Southwest Exit and running downwards from the Level 14 Northeast Exit in the 18 level Forsyth Barr Building either fell during, or were removed following, the earthquake After-shock on 22 February, 2011.

### RESULTS OF THE STAIRWELL AND STAIR REMNANTS EXAMINATIONS

The stairs were undergoing refurbishment at the time of the After-shock, after reportedly having suffered some damage in the 4 September, 2010 Earthquake.

The bottom landings of a number of the stair flights had damage consistent with having engaged horizontally end-on with their supporting beams or items such as polystyrene construction packers, construction debris or mortar infill strips in the seismic gaps which hindered them from sliding horizontally as the building moved back and forth in that direction during the After-shock.

Bending and shearing damage induced rotations in the lower landings was observed in some of the stair flights remaining in the stairwell and also in remnants that had been retrieved from the stairwell.

The fractured D20 reinforcing steel at the top supports of the stair flights from which the stair flights had broken away was visible (Figure 1).

During the Stairwell Examination some of the remaining flights were observed to have slumped noticeably by up to 55 mm at the junction of the bottom landing with the first stair riser.

A seismic gap of 30 mm was specified on the Drawings held by the Council to accommodate the differential horizontal movement between the adjacent floor levels that is widely known to occur in earthquakes. The Drawings did not show what construction tolerances were to be allowed for by the builder with respect to the seismic gap and it is not known how well the 30 mm gap was achieved during construction for all the stair flights.

During the Stairwell Examination a polystyrene construction packer was found in the gap in one of the remaining stair flights. In that instance it had not been subsequently removed to provide the specified gap shown in the Drawings (Figure 2).

It was also found that the seismic gaps had also been compromised in a number of instances by the installation of a rigid mortar strip up to 30 mm thick seated on expanded foam rods, rather than being filled with flexible sealant as specified in the Drawings (Figure 4).

It was observed that where the seismic gaps at the lower landings of the stair flights had been compromised by the installation of the rigid mortar strip, the ends of the landings had also been saw-cut. In one instance this was measured to be 25 mm (Figure 3). This saw-cutting would have been ineffective in increasing the seismic gap, as the saw cuts stopped above the 80 mm x 80 mm steel seating angle on the bottom edge of the precast landing.

## FORSYTH BARR BUILDING STAIRS SITE EXAMINATION AND MATERIALS TESTS

## EXECUTIVE SUMMARY

continued

During the Stair Remnants Examination of stair flights retrieved from the stair well it was observed that a number of stair flight lower landings had also been saw cut.

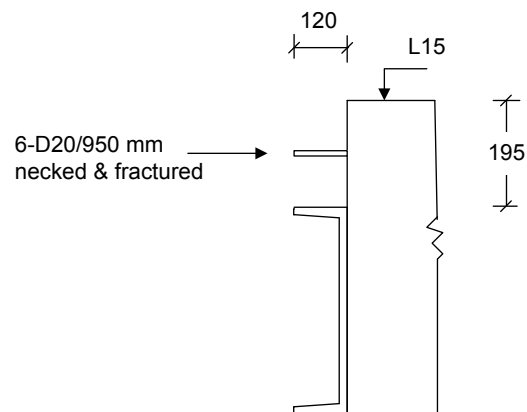

Figure 1 – Level 15 Southwest Exit L15 to L14 stair upper landing with fractured D20 reinforcing steel above 381x102 mm RSC steel channel support

## FORSYTH BARR BUILDING STAIRS SITE EXAMINATION AND MATERIALS TESTS

## EXECUTIVE SUMMARY

continued

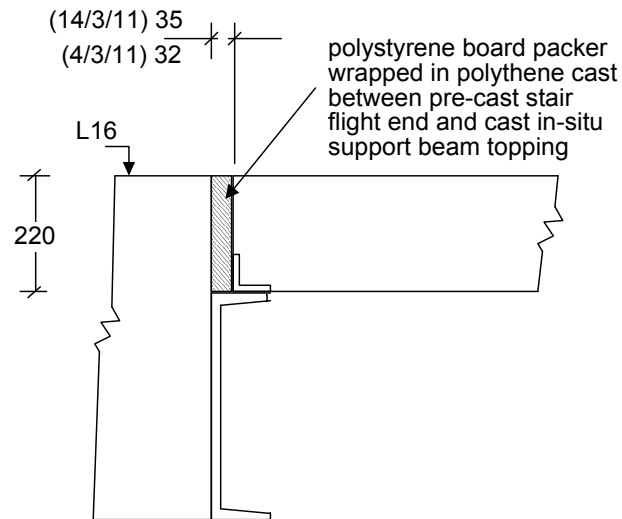

Figure 2 - Level 16 Northeast Exit L 16 to L 17 Stair Flight lower landing and support: (photos from left to right): (a) Polythene wrapped polystyrene packer in seismic gap; (b) Seismic gap with packer removed during Stairwell Examination showing in-situ casting marks on support beam topping from packer wrapping.

## FORSYTH BARR BUILDING STAIRS SITE EXAMINATION AND MATERIALS TESTS

## EXECUTIVE SUMMARY

continued

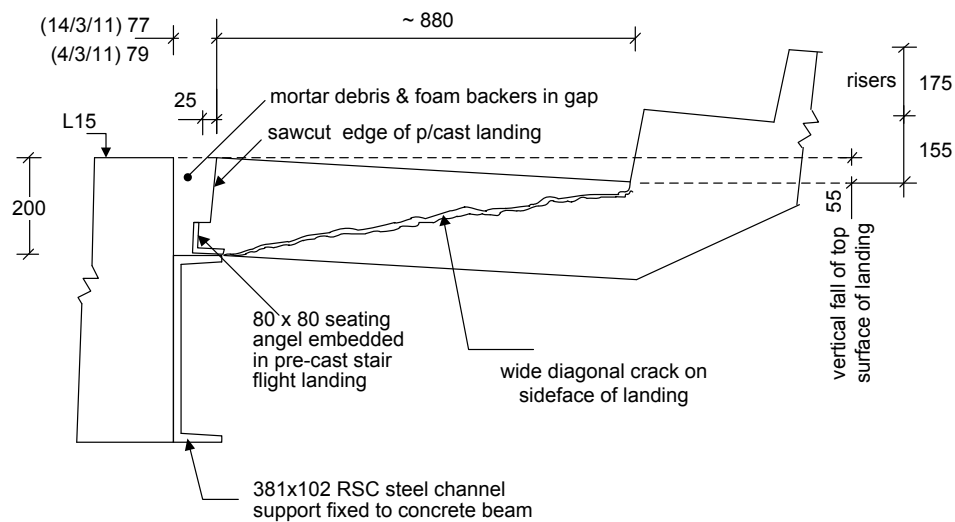

Figure 3 - Level 15 Southwest Exit LI5 to LI6 stair lower landing and support: (photos clockwise from top left): (a) Diagonal crack in the side face of the stair flight landing with expanded foam tube caught in it; (b) Seismic gap with debris removed showing saw-cut end and ledge at seating angle; (c) Seismic gap measurement with debris; (d) Vertical slumping of the landing at the first riser



## RESULTS OF MATERIALS TESTING

### Reinforcing Steel

The reinforcing steel tested in the investigation complied with the requirements of the standard applicable at the time of construction (NZS 3402P:1973 Grade 275). This required a minimum yield stress of 275 MPa, ultimate tensile strength between 380 and 520 MPa, and minimum elongation after fracture of 12% on a gauge length of 5 bar diameters

### Concrete

Concrete cores were extracted and tested from two stair flight remnants. The average compressive strength from the three cores was  $f_c' = 46.5$  MPa, with a minimum of 43.0 and maximum of 50.0 MPa. It is not known what the specified 28 day strengths for the stair flights was, however test results are greater than  $f_c' = 30$  MPa which was commonly specified for stair flights.

With account for grade variation and aging the expected column concrete strength at 28 day would have been approximately 30 MPa.

The stair flight concrete tested therefore had concrete strengths consistent with design practices of the times.

### Seismic Gap Mortar

The rigid mortar infill strip was found from testing to have compressive strength of 20.4 MPa.

For an average measured strip thickness of 22 mm the mortar strip would have been able to restrict movement induced actions of up to a maximum of 435 kN while it remained in place (Figure 4).

FORSYTH BARR BUILDING STAIRS SITE EXAMINATION AND MATERIALS TESTS

EXECUTIVE SUMMARY

continued

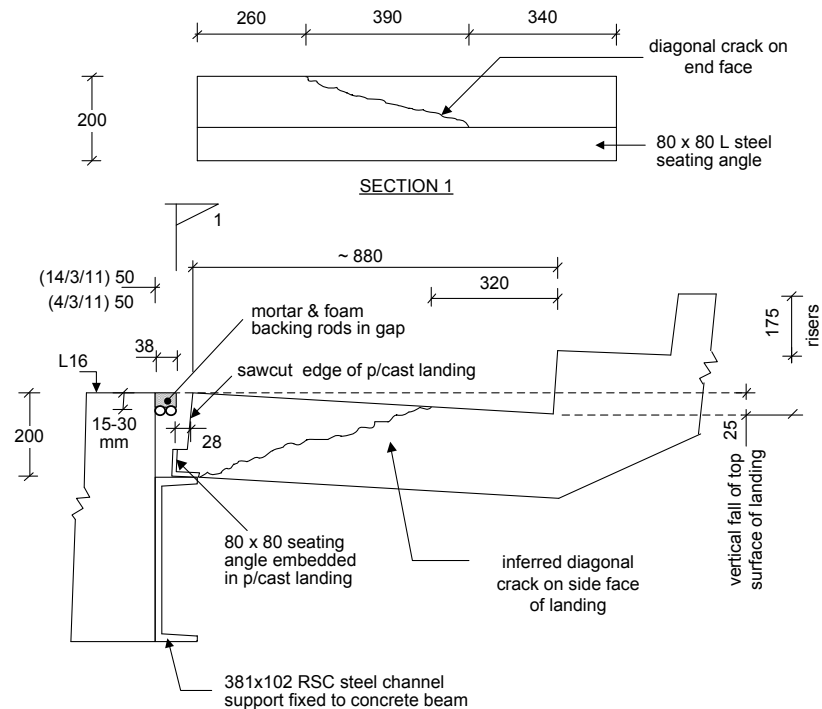

Figure 4 - Level I6 Southwest Exit L16 to L17 Stair Flight lower landing and support: (clockwise photos from top left): (a) 25 mm drop in landing at first riser; (b) Diagonal crack along top face of landing; (c) Adjoining diagonal crack in sawn face of precast landing; (d) 38 mm wide mortar remnant held back in original location.

## TECHNICAL SUMMARY

The following is a summary of important observations made during the Stairwell Examination within the Forsyth Barr Tower on 14 March 2011 and the Stair Remnants Examination in the adjacent car parking area on 15 March, 2011:

- a. The stairs were undergoing refurbishment at the time of the 22 February 2011 After-shock, after sustaining some damage in the 4th September 2010 Earthquake.
- b. The concrete scissor stairs collapsed or had been demolished by other parties to allow safe salvage below, from Level 15 down. Some of the lower-most flights remained in place.
- c. Each flight of stairs was shown on the Drawings as consisting of two precast half flights with a mid-height in-situ landing (Figure 36; Figure 37). However it appears that the stair flights were precast as one continuous unit as no construction joint could be seen in Units 8, 14 and 18 at the mid-height landing (Figure 23; Figure 29; Figure 33). The top end of the flight rested on a 381 mm x 102 mm RSC (rolled steel channel) and was cast into the building floor concrete (Figure 39). The bottom end of the precast flight sat on a 381 x 102 RSC steel channel with nominally 75 mm seating and detailed to allow 30 mm of horizontal compression movement between the stair and the lower floor (Figure 38). The typical design floor to floor height between Level 4 and 18 was documented as 3500 mm.
- d. The lower landings of stair flights that had remained in place at the time of the Stairwell Examination at the Level 15 Southwest Exit showed severe diagonal cracking on the sides and ends consistent with compressive horizontal thrust of the stair landing on the supporting concrete beam (Figure 3) At the Level 16 Southwest Exit similar damage was inferred to have occurred (Figure 4). Similar damage was observed on stair remnant unit 17 during the Stair Remnants Examination (Figure 32). Significant flexural compressive - shear damage was also observed at the bottom riser junction with the lower landings in stair remnants unit 1, 11, 13 and 15 (Figure 16; Figure 26; Figure 28; and Figure 30).
- e. The L15 to L16 stair flight observed at the Level 15 Southwest Exit had visibly slumped downwards 55 mm at the junction of the lower landing to the first riser (Figure 3). At Level 16 Southwest Exit the lower landing of the L16 to L17 stair flight had dropped 25 mm at the junction of the landing with the first riser (Figure 4).
- f. At the upper supports from which stairs had fallen, the necked and fractured ends of six D20 reinforcing steel bars protruded 120 mm out of the concrete beams, just past the tip of the supporting 102

## FORSYTH BARR BUILDING STAIRS SITE EXAMINATION AND MATERIALS TESTS

## TECHNICAL SUMMARY

continued

- mm wide flange of the supporting 381 × 102 RSC steel channel. The steel channel had not suffered any obvious damage (Figure 1).
- g. The ends of a number of lower landings of the stair flights had been saw-cut. However the saw-cutting stopped above the 80 mm × 80 mm steel seating angle embedded in the end of the landings, resulting in no change to the seismic separation gap at the base of the landing.
  - h. The gap at the top of these saw-cut landings had been filled with up to 30 mm thick of mortar on expandable foam backing rods (Figure 4 and Figure 11). This mortar strip was found by testing to have an average compressive strength of 20.4 MPa. This compromised the ability of the stairs to slide and was evidently strong enough to transmit compressive actions sufficient to cause damage to the landings. Mortar debris was also found in the gaps of some saw-cut landings.
  - i. The horizontal gaps at the lower landings of the stair flights were measured by other parties on 4 March 2011 and were re-measured during this Stairwell Examination on 14 March 2011. In most cases little or no further movement had occurred between measurements.
  - j. During the Stair Remnants Examination Units 1, 10, 11, 13, 15 and 17 were observed to have similar lower landing damage at the first riser junction as seen during the Stairwell Examination in the damaged stairs remaining in place.
  - k. Prior to removing the collapsed stair remnants from the stairwell, one flight of stairs was apparently cut free by other parties using a thermal lance, as it was hanging down from its top landing. Another stair flight was apparently saw-cut from its top support as it was only seated by a few millimetres on its bottom landing.
  - l. Concrete compression tests by Opus Laboratories found the concrete from the stairs to have average cylinder strength of 46.5 MPa.
  - m. Steel reinforcing tensile tests by SAI Global showed the reinforcing steel to have properties consistent with the grade G275 reinforcing steel standard AS/NZS 3402P:1973, applicable at the time of construction.



## FORSYTH BARR BUILDING STAIRS SITE EXAMINATION AND MATERIALS TESTS

## TECHNICAL SUMMARY

continued



Figure 5 –Crane access into building

Disclaimer:

The observations made in this report cover only a portion of the stairwell able to be accessed at the time of the Stairwell Examination and a sample of stair remnants able to be observed during the Stair Remnants Examination. The observations therefore should be interpreted in conjunction with the original structural design drawings and specification, and modifications that may have occurred prior to the After-shock, as well as photos and observations of the stairwell immediately after the After-shock and during its subsequent removal of stair remnants.

The damage also needs to be interpreted in the context of the effects of impact from stairs falling on them from above, or from themselves hitting the ground, and damage incurred during retrieval from the stairwell.

The sufficiency of the specified horizontal seismic gap intended to accommodate the differential horizontal movement between the adjacent floor levels has not been checked as part of this report.

The reinforcing steel tested may have been subjected to in-service stresses or stresses induced during collapse or retrieval that affected its tested properties.

Examination and assessment of damage to the building structure as a whole was outside the scope of the Stairwell Examination and this report.



## I. INTRODUCTION

### A. OBJECTIVE

The objective of this report was to determine the condition of the stairs remaining in the stair well and try to identify possible causes of the damage to and collapse of the stair flights during the After-shock on 22 February, 2011 ("the After-shock"), for further investigation and analysis by other parties.

### B. SCOPE

The Department of Building and Housing set out the following scope for the investigation:

- Retrieve relevant drawings of the structure and stairs from the Christchurch City Council ("the Council") document storage facility.
- Access the interior of the building by external crane.
- Visual examination of remaining stair flights and support structures.
- Layout and visually examine and document collapsed stair remnants salvaged from the stair well.
- Remove samples of reinforcing steel and concrete cores for code conformance checks and possible back engineering of the collapse condition.
- Report on findings.

No examination or assessment of the condition of other parts of the structure or its conformance with the Drawings was undertaken.

### C. BACKGROUND

The building permit drawings stamped by the Council with the date 26 April, 1988 ("the Drawings") for the Forsyth Barr Building show an 18 level perimeter frame reinforced concrete building with pre-stressed concrete rib floors with in-fill timber permanent formwork (Figure 35 Appendix E). There was no shear wall core.

The stairs were reported by other parties to have been damaged in the 4 September 2010 Earthquake ("the Earthquake") and notices on some stairwell exits indicated they were being refurbished at the time of the 22 February 2011 After-shock.

The stairwell is located at the rear of the lift shaft on the southeast corner of the building and consists of two sets of stairs arranged in scissor fashion aligned southwest to northeast, that were separated by light-weight fire rated walls (Figure 36 Appendix E).

By way of explanation, the arrangement of the scissor stairs was such that a set of stairs could for example be accessed from the northeast exit door on a nominal floor level B, and then from the southwest exit door on the next floor level above or below. The other set of stairs in the stair well could conversely be accessed from



## FORSYTH BARR BUILDING STAIRS SITE EXAMINATION AND MATERIALS TESTS

## INTRODUCTION

continued

the southwest exit door on the same floor level B, and then from the northeast exit on the next floor level above or below. A person walking up one flight of stairs in the stair well would not meet a person coming down the other flight of stairs.

The Drawings show that the stairs flights were permitted to consist of two precast concrete units joined by in-situ concrete at a mid-height landing (Figure 37 Appendix E). The upper portion of each stair flight was seated on a 381x102 mm RSC steel channel section and had six D20 reinforcing bars cast into the upper concrete support beam (Figure 39 Appendix E). The lower portion of each stair flight sat on a 381x102 mm RSC steel channel section.

A 30 mm seismic gap was specified on the Drawings at the lower landings of the stair flights to allow the stair flights to slide freely back and forth and take up any inter-storey drift movements induced by an earthquake without damaging the stair or falling off the lower landings supports (Figure 38 Appendix E).

The Stair Remnants Examination found no evidence of there being a construction joint at the mid-height landings. The author considers that the stair flights were therefore cast as single pre-cast units able to be installed to span directly from the lower to the upper support without any temporary propping. The top bars from the pre-cast stair flights were then cast into the upper support.





## 2. STAIRWELL EXAMINATION

The author and others gained access to the building on the evening of Monday 14 March, 2011, to observe the condition of stairs remaining in the stairwell (“the Stairwell Examination”).

Access was gained externally by crane (Figure 5) consecutively into Levels 15, 16, and 17, then up to the roof internally using the remaining stairs.

Level 12 and Level 9 were then entered externally by crane and the stairwell also examined there.

It was reported to the author that prior to the Stairwell Examination, during retrieval of the collapsed remnants from the stair well by other parties, one stair flight had been found hanging down vertically from its upper support. This had then been cut free using a thermal lance. Another stair had also apparently been found at the same time to have had only minimal bearing on its bottom support steel channel and had also been cut free using a concrete saw.

For the purposes of this report the stair exits on each floor level are designated as “the Northeast Exit” or “the Southwest Exit” (Figure 35 Appendix E). For example the Level 9 Southwest Exit occurs on Level 9 at the southwest end of the stair well.

The stair flights examined at each stairwell exit are designated using the floor level at the exit and the floor level at its landing on the next adjacent floor (ie “Level 15 Northeast Exit L15 to L16 Stair Flight” means the stair flight running up from Level 15 to 16 as seen from the northeast stair exit on Level 15. Similarly the “Level 15 Northeast Exit L15 to L14 Stair Flight” is the flight running down from Level 15 to 14 as seen from the northeast stair exit on Level 15.)

Within the stair well the stair flights on the northwest (or inner) wall run upwards from the southwest exit landings, and the stair flights on the southeast (or outer) wall run upwards from the northeast exit landings.

The following sections describe the observations made during the Stairwell Examination at each stairwell exit visited.

### Disclaimer:

The Stairwell Examination was limited by scope and time, so no attempt was made to assess the structural condition of the building structure as a whole.

## FORSYTH BARR BUILDING STAIRS SITE EXAMINATION AND MATERIALS TESTS

## STAIRWELL EXAMINATION

continued

**A. LEVEL 9 SOUTHWEST EXIT****i. Level 9 Southwest Exit L9 to L10 Stair Flight**

This stair flight had fallen away. The 381 x 102 RSC support channel appeared to be undamaged.

**ii. Level 9 Southwest Exit L9 to L8 Stair Flight**

The stair flight running from Level 9 down to Level 8 had fallen away. The 381 x 102 RSC support channel appeared to be undamaged.

Necked and fractured reinforcing bars are left with 110 mm stick out from the upper, similar to what was seen on other upper landing supports (Figure 1).

It is likely that this stair collapsed after it was hit by stairs falling from above judging by the tearing pattern in the lino (Figure 6).



Figure 6 - Level 9 Southwest Exit L9 to L8 Stair Flight upper support with fractured D20 reinforcing and lino that appears to have been torn by stairs falling from above

## FORSYTH BARR BUILDING STAIRS SITE EXAMINATION AND MATERIALS TESTS

## STAIRWELL EXAMINATION

continued

**B. LEVEL 12 NORTHEAST EXIT****i. Level 12 Northeast Exit L12 to L11 Stair Flight**

The stair flight had fallen away. The 381 x 102 RSC support channel appeared to be undamaged.

Six D20 bars spaced equally over 950 mm can be seen in the upper support of the Level 12 to 11 stair flight (Figure 7).

One bar had de-bonded from the precast stair whereas the other five D20 bars have necked and fractured in a similar manner to other landing supports. The remaining D20 bar stubs extend 120 mm out from the supporting concrete beam face.

**ii. Level 12 Northeast Exit L12 to L13 Stair Flight**

The stair flight had fallen away. The 381 x 102 RSC support channel appeared to be undamaged.



Figure 7 -Level 12 Northeast Exit L12 to L11 stair flight upper support with one de-bonded bar and five fractured D20 bars extending out from the support beam. The 381 x 102 RSC steel channel is undamaged and continues over to the L12 to L13 lower support.

## FORSYTH BARR BUILDING STAIRS SITE EXAMINATION AND MATERIALS TESTS

## STAIRWELL EXAMINATION

continued

**C. LEVEL 15 NORTHEAST EXIT****i. Level 15 Northeast Exit L15 to L16 Stair Flight**

The L15 to L16 stair lower landing had a gap of 50mm measured. The measurement written on the landing by other parties on 4 March, 2011 was 55 mm (2 3/16 ") (Figure 8).

The mid-height landing had dropped noticeably from the black finishing strip set at the original landing height (Figure 9).

**ii. Level 15 Northeast Exit L15 to L14 Stair Flight**

The stair flight was still in place but was not examined below its upper supports from this location for safety reasons. This stair flight could also be seen below the Level 15 Southwest Exit L15 to L16 Stair Flight (Figure 10).

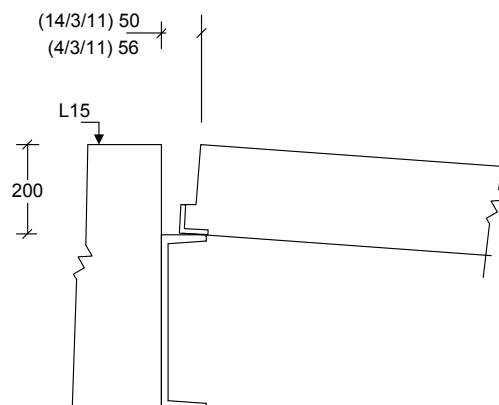

Figure 8 - Level 15 Northeast Exit L15 to L16 Stair Flight lower landing seismic gap

## FORSYTH BARR BUILDING STAIRS SITE EXAMINATION AND MATERIALS TESTS

## STAIRWELL EXAMINATION

continued



Figure 9 - Level 15 Northeast Exit L15 to L16 Stair Flight showing vertical displacement at mid-height landing relative to black finishing strip.

## FORSYTH BARR BUILDING STAIRS SITE EXAMINATION AND MATERIALS TESTS

## STAIRWELL EXAMINATION

continued

**D. LEVEL 15 SOUTHWEST EXIT****i. Level 15 Southwest Exit L15 to L14 Stair Flight**

The stair flight had fallen away and six D20 bars spaced evenly over 950 mm were exposed that had necked and fractured 120 mm from the edge of the concrete slab above the edge of the 102 mm wide top flange of the 381x102 mm RSC steel channel supporting it.

The top flange of the RSC steel channel appeared to be undamaged (Figure 1).

There is a void where the stair flight had fallen away (Figure 10).



Figure 10 - Level 15 Southwest Exit: (photos from left): (a) Remaining Level 15 Southwest Exit L15 to L16 stair flight lower landing with the remaining Level 14 Southwest Exit L14 to L15 Stair Flight able to be seen directly below. All flights below and including the Level 15 Southwest Exit Level 15 to 14 stair flight have fallen away; (b) Fractured reinforcing remnants at upper support of the Level 15 Southwest Exit L15 to L14 flight which has fallen away.

**ii. Level 15 Southwest Exit L15 to L16 Stair Flight**

A large wide diagonal crack had formed on the side face of the stair landing. A piece of expanded foam material had been caught in it.

The landing itself had dropped noticeably at the junction between the landing and the first stair riser.

The L15 to L16 stair flight had a lower landing gap at top of slab of 77 mm. This compared with 79 mm (3 1/8") measured and written on the landing by other parties on 4 March, 2011.

The end face of the precast landing had been saw cut down to the top of the 80 mm x 80 mm steel seating angle. Mortar debris was removed by the author from the gap during the Stairwell Examination (Figure 3).

## E. LEVEL 16 SOUTHWEST EXIT

### i. Level 16 Southwest Exit L16 to L17 Stair Flight

The lower landing had a diagonal crack on the top surface that linked to a matching one on the end face. It is therefore surmised that a corresponding diagonal crack occurred on the side face. But this was obscured by the upper L16 to L15 stair flight landing which was still in place (Figure 4).

The lower landing had a gap at the seismic joint measured at the top of slab of 50 mm. This compared with 50 mm (2") measured and written on the landing by other parties on 4 March, 2011.

The precast landing had dropped 25 mm at the junction of the landing with the first riser.

The end of the precast landing had been saw-cut down to the top of the 80 mm x 80 mm steel seating angle.

Mortar remnants up to 30 mm thick and 38 mm wide were found that had been supported by two expanded foam rods over part of the seismic gap. Mortar debris was also found in the gap.

Compressive strength testing of the mortar strip by Opus International Consultants Ltd Christchurch Laboratory, ("Opus Laboratories Christchurch") found it to have an average compressive strength of 20.4 MPa.

### ii. Level 16 Southwest Exit L16 to L15 Stair Flight

This stair flight was still in place but was not examined from this location below its upper support for safety reasons. However the condition of its lower landing is described in the Level 15 Northeast Exit L15 to L16 Stair Flight inspection (Figure 8 and Figure 9).

(Note: The author also recalls that the overlay veneer floor in the lift lobby area at either Level 15 or Level 16 had sprung up.)

## FORSYTH BARR BUILDING STAIRS SITE EXAMINATION AND MATERIALS TESTS

## STAIRWELL EXAMINATION

continued

**F. LEVEL 16 NORTHEAST EXIT****i. Level 16 Northeast Exit L16 to L17 Stair Flight**

A polythene wrapped polystyrene construction packer was found in this seismic gap. The packer was removed during the Stairwell Examination revealing casting marks on the support slab which was evidence that it had been installed during the original construction of the stairs.

The lower landing of the stair flight had not been saw-cut on this stair.

The stair flight had a lower landing gap at top of slab measured as 35 mm. This compared with 32 mm (1 1/4") measured and written on the landing by other parties on 4 March, 2011.

**ii. Level 16 Northeast Exit L16 to L15 Stair Flight**

This stair flight remained in place but was not examined below its upper support from this location due to safety reasons. However the condition of its lower landing is described in the Level 12 Southwest Exit L15 to L16 Stair Flight section (Figure 3).





## FORSYTH BARR BUILDING STAIRS SITE EXAMINATION AND MATERIALS TESTS

## STAIRWELL EXAMINATION

continued

**G. LEVEL 17 NORTHEAST EXIT****i. Level 17 Northeast Exit L17 to L18 Stair Flight**

No obvious damage had occurred in the After-shock. No saw cutting had occurred to the end of the precast stair flight lower landing.

The seismic gap had a mortar filling strip layer at floor level.

The L17 to L18 stair flight had a lower landing gap measured at the top of the slab of 60 mm. This compared with 62 mm (2 7/16") measured and written on the floor by other parties on 4 March, 2011.

**ii. Level 17 Northeast Exit L17 to L16 Stair Flight**

The stair flight was still in place but was not examined below its upper supports from this location for safety reasons. However the condition of its lower landing is described in the Level 16 Southwest Exit L16 to L17 Stair Flight section (Figure 4).



Figure 11 - Level 17 Northeast Exit (left to right) (a) L17 to L18 stair flight seismic gap measurement where a portion of the mortar strip had been removed previously by other parties; L17 to L16 stair flight in foreground. (b) Extent of remaining mortar filling of seismic joint of L17 to L18 stair flight.



### 3. STAIR REMNANTS EXAMINATION

#### A. SUMMARY

The collapsed stair remnants had been removed from the stairwell at Level 1 and 2 (Figure 13) by other parties and placed in the car park behind the Forsyth Barr building prior to the Stair Remnants Examination (Figure 12).

These stair remnants were inspected by the author and a DBH engineer during the Stair Remnants Examination on the 15 March, 2011, are described in the photos in Figure 15 to Figure 34 of Appendix A.

#### Disclaimer:

The stair remnants were marked with unit numbers during the Stair Remnants Examination to facilitate referencing for this report. They are not knowingly associated with any particular stair flight or floor. The damage to the stair remnants needs to be interpreted in conjunction with the knowledge that the stairs had typically been broken up by other parties at the mid-height landings to aid removal from the stair well. Damage from the impact of stairs falling on top of each other needs also to be considered.



Figure 12 - Stair remnant debris in car park behind Forsyth Barr building after their removal from the stairwell.

FORSYTH BARR BUILDING STAIRS SITE EXAMINATION AND MATERIALS TESTS

STAIR REMNANTS EXAMINATION

continued



Figure 13 - Access into stairwell from Level 1 and 2 used for removal of stair remnants

## FORSYTH BARR BUILDING STAIRS SITE EXAMINATION AND MATERIALS TESTS

## STAIR REMNANTS EXAMINATION

continued

**B. STAIRWELL ACCESS FOR STAIR REMNANT RETRIEVAL**

The stair remnants had been retrieved by other parties from Level 1 and 2 of the stair well (Figure 13 and Figure 14).



Figure 14 – Level 2 to 3 Stairwell in the access area used for remnant retrieval

**C. UPPER LANDING REINFORCING FRACTURES IN STAIRS**

Necked and fractured reinforcing steel at the precast stair upper landings corresponding to that found in the stairwell supports was observed in a number of the stair remnants (Figure 15).



Figure 15 - Upper landing reinforcing steel fractures matching those seen in the stairwell supports. The steel seating angle to the underside and end of the stair flight landing is visible at the top



## 4. MATERIALS PROPERTIES

### A. REINFORCING STEEL

D20 reinforcing steel samples were taken from the stair remnant Unit 10 (Figure 25), along with D12 transverse bars from a landing. These were tested by SAI Global (NZ) Limited ("SAI Global") as reported in Appendix B.

The D12 reinforcing had an average yield stress  $R_e$  of 327 MPa, with a minimum of 325 MPa and maximum of 329 MPa.

The D12 reinforcing had an average ultimate tensile strength  $R_m$  of 448 MPa, with a minimum of 442 MPa and maximum of 455 MPa.

The D20 reinforcing had an average yield stress  $R_e$  of 325 MPa, with a minimum of 321 MPa and maximum of 323 MPa.

The D20 reinforcing had an average ultimate tensile strength  $R_m$  of 454 MPa, with a minimum of 452 MPa and maximum of 458 MPa.

The reinforcing steel tested complied with the requirements of NZS 3402P:1973 G275 (SNZ 1973) applicable at the time of construction. This required minimum yield stress of 275 MPa; ultimate tensile strength between 380 and 520 MPa; and minimum elongation after fracture of 12% on a gauge length of 5 bar diameters.

#### Disclaimer:

The reinforcing steel tested may have been subjected to in-service stresses or stresses induced during collapse or retrieval that affected its tested properties.

### B. CONCRETE CORES

Testing of concrete cores cut from Units 1 and 2 was undertaken by Opus International Consultants Limited Christchurch Laboratory ("Opus Laboratories") (as reported in Appendix C).

Concrete is widely known in the construction industry to strength-age or increase in strength over time. The amount of strength-aging is dependent on the mix design, batching, placement and curing practices. There is no quantitative relationship currently known for concrete manufactured in Christchurch. However the California Department of Transportation (Caltrans) found that in California concrete with 20 to 25 MPa specified 28 day strength had at least 25% strength –aging over 20 to 30 years. Concrete batching practice typically sought to achieve a target strength 20% greater than the specified 28 day cylinder compressive strength. This led to the use of a divisor of 1.5 on the strength-aged specimen test results to approximate the specified 28 day compressive strength (Priestley, Seible et al. 1996).

Average compressive strength from the three cores was  $f_c' = 46.5$  MPa, with a minimum of 43.0 and maximum of 50.0 MPa. It is not known what the specified 28 day strengths for the stair flights was, however this is greater than 30 MPa commonly specified for stair flights.

## FORSYTH BARR BUILDING STAIRS SITE EXAMINATION AND MATERIALS TESTS

MATERIALS PROPERTIES

continued

With account for grade variation and aging the expected column concrete strength at 28 day would have been approximately 30 MPa.

The stair flight concrete tested therefore had concrete strengths consistent with design practices of the times.

**C. SEISMIC GAP MORTAR STRIP COMPRESSIVE STRENGTH**

Testing by Opus Laboratories of mortar cut from a strip, recovered by the author from the stairwell, shows that the mortar had an average columnar compressive strength of 20.4 MPa, with a minimum of 19.1 and maximum of 21.1 MPa. The results are reported in Appendix D,

For an average measured strip thickness of 22 mm the mortar strip would therefore have been able to restrict movement induced actions of up to a maximum of 435 kN while it remained in place.





## 5. CONCLUSIONS

Observations made during the Stairwell Examination and the Stair Remnants Examination found that the lower landings of some of the stair flights were damaged after they impacted horizontally with their supporting beams, or were prevented from adequately sliding in that direction by items such as construction packers, construction debris, or mortar strips which compromised the seismic gap.

This damage was observed to have caused slumping in some of the remaining stair flights in the stairwell.

Units 1, 10, 11, 13, 15 and 17 had severely damaged lower landings at the first riser junction that the author considers to have been caused in this way

Stair remnant Units 8, 14 and 18 showed no sign of a construction joint at the mid-height landing, so the author considers that the flights were precast as single units and installed to span between the lower and upper landing support beams without propping. Their top bars would then have been cast into the upper landing.

It is also possible that some of the stair flights may have become dislodged without compressive damage from their lower landing seating, if the 75 mm nominal seating, less installation allowances, was less than the relative movement of the upper floor away from the lower floor. However this was not able to be established from the Stair Remnants Examination.

Further analysis beyond the scope of this report is required to determine the collapse sequence.

### Disclaimer:

The observations made in this report cover only a portion of the stairwell able to be accessed at the time of the Stairwell Examination and a sample of stair remnants able to be observed during the Stair Remnants Examination. The observations therefore need to be interpreted in conjunction with the original structural design drawings and specification, and modifications that may have occurred prior to the After-shock, as well as photos and observations of the stairwell immediately after the After-shock and during its subsequent removal of stair remnants.

The damage to the stair remnants observed during the Stair Remnant Examination needs to be interpreted in the context of possible falling damage and retrieval damage.

It is likely that once one stair flight fell it caused the consequential collapse of other stair flights below as it hit them on the way down. This effect needs to be considered in interpreting the observed damage.

Some of the damage observed and documented in this report may have occurred during the removal of the stair remnants from the stairwell.

The sufficiency of the specified horizontal seismic gap intended to accommodate the differential horizontal movement between the adjacent floor levels has not been checked as part of this report.



## FORSYTH BARR BUILDING STAIRS SITE EXAMINATION AND MATERIALS TESTS

## CONCLUSIONS

continued

---

Examination and assessment of damage to the building structure as a whole was outside the scope of the Stairwell Examination and this report.



FORSYTH BARR BUILDING STAIRS SITE EXAMINATION AND MATERIALS TESTS

## 6. REFERENCES

Priestley, M. J. N., F. Seible, et al. (1996). Seismic Design and Retrofit of Bridges, John Wiley.

SNZ (1973). Hot Rolled Steel Bars for the Reinforcement of Concrete NZS 3402P:1973. Wellington, Standards New Zealand.





## FORSYTH BARR BUILDING STAIRS SITE EXAMINATION AND MATERIALS TESTS

## APPENDIX A - SALVAGED STAIR REMNANT PHOTOS

### A. UNIT 1



Figure 16 - Unit 1 (clockwise from top): (a) Flexural damage at underside of lower landing; (b) Flexural cracks in underside above lower landing; (c) Concrete core test location in tread.

### B. UNIT 2



Figure 17 - Unit 2 showing concrete core test locations on the sides of treads

## FORSYTH BARR BUILDING STAIRS SITE EXAMINATION AND MATERIALS TEST

## APPENDIX A - SALVAGED STAIR REMNANT PHOTOS

continued

## C. UNIT 3



Figure 18 - Unit 3 with upper landing; Unit 1 to left behind; Unit 2 to right behind

## D. UNIT 4



Figure 19 - Unit 4 (left to right): (a) De-bonded top landing bars (possibly from Level 2); (b) Cracks across stair throat at toes of risers.

## FORSYTH BARR BUILDING STAIRS SITE EXAMINATION AND MATERIALS TEST

## APPENDIX A - SALVAGED STAIR REMNANT PHOTOS

continued

## E. UNIT 5

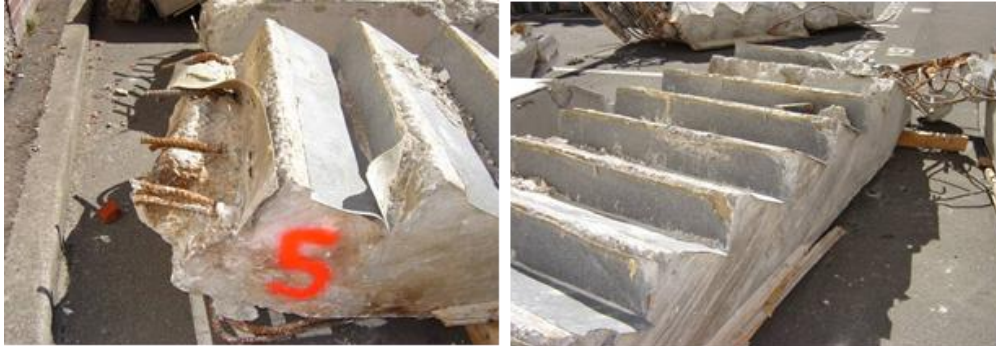

Figure 20 - Unit 5 (Clockwise from top left): (a) Gas cut rebar at mid-height landing; (b) Damaged upper landing.

## F. UNIT 6



Figure 21 - Unit 6 broken up and gas cut landing. 30 to 50 mm cover to ten D20 reinforcing at underside of lower landing. The Unit 7 upper landing is at the right.

## FORSYTH BARR BUILDING STAIRS SITE EXAMINATION AND MATERIALS TEST

## APPENDIX A - SALVAGED STAIR REMNANT PHOTOS

continued

**G. UNIT 7**

Figure 22 - Unit 7 (left to right): (a) Gas cut mid-height landing bars. Cracks across throat at toe of risers; (b) Damaged upper landing steel seating angle.

**H. UNIT 8**

Figure 23 - Unit 8 (left to right): (a) 300 mm long upper landing with 45 degree shear crack and damaged seating angle. Fractured D20 bar remnants in end face; (b) Gas cut mid-height landing b.

**I. UNIT 9**

Figure 24 - Unit 9 (Left to right): (a) Damaged upper landing; (b) Damaged mid-height landing with crushed concrete and de-bonded reinforcing.



## FORSYTH BARR BUILDING STAIRS SITE EXAMINATION AND MATERIALS TEST

## APPENDIX A - SALVAGED STAIR REMNANT PHOTOS

continued

**J. UNIT 10**

Figure 25 - Unit 10 (left to right): (a) Underside near mid-height landing where D20 reinforcing steel samples were extracted for testing; (b) Damaged lower landing.

**K. UNIT 11**

Figure 26 - Unit 11 (left to right): (a) Damaged mid-height landing with hooked bottom bars (bars not gas cut); (b) Bottom rebar gas cut at lower landing junction to first riser.

## FORSYTH BARR BUILDING STAIRS SITE EXAMINATION AND MATERIALS TEST

## APPENDIX A - SALVAGED STAIR REMNANT PHOTOS

continued

## L. UNIT 12



Figure 27 - Unit 12 (left to right): (a) Mid-height landing; (b) Lower landing.

## M. UNIT 13



Figure 28 - Unit 13 (left to right): (a) Mid-height landing; (b) Lower landing 600-700 mm long with flexural damage at first riser

## N. UNIT 14



Figure 29 - Unit 14 (Left to right): (a) Mid-height landing bars gas cut; (b) Lower landing intact.

## FORSYTH BARR BUILDING STAIRS SITE EXAMINATION AND MATERIALS TEST

## APPENDIX A - SALVAGED STAIR REMNANT PHOTOS

continued

## O. UNIT 15



Figure 30 - Unit 15 (Left to right): (a) Damaged mid-height landing with hooked bottom bars; (b) Gas cut bars at lower landing which has broken away near first riser.

## P. UNIT 16



Figure 31 - Unit 16 (left to right): (a) Mid-height landing bars gas cut; (b) Damaged upper landing.

## Q. UNIT 17



Figure 32 - Unit 17 (Left to right): (a) Lower landing with compression support lateral impact shear cracking and saw cut end; (b) Mid-height landing ten D20 bottom bars bent and developed to underside of second riser below landing exposed, four D20 top bar stubs visible.

## FORSYTH BARR BUILDING STAIRS SITE EXAMINATION AND MATERIALS TEST

## APPENDIX A - SALVAGED STAIR REMNANT PHOTOS

continued

## R. UNIT 18



Figure 33 - Unit 18 (Left to right): (a) Gas cut bars at mid-height landing. No construction joint apparent in side face indicating stair was precast as one unit; (b) Cut support bars at upper landing.

## S. OTHER STAIR REMNANTS







Figure 34 – Other stair remnants.

FORSYTH BARR BUILDING STAIRS SITE EXAMINATION AND MATERIALS TESTS

## APPENDIX B - REINFORCING STEEL TEST RESULTS

(Reproduced with permission)

	Date of Issue: 23 March 2011 Reference: P5673 Page 1 of 3 Pages
<h1>TEST REPORT</h1>	
<b>CUSTOMER:</b>	Hyland Consultants Ltd P O Box 97282 Manukau Auckland 2241  Attention: Dr Clark Hyland
<b>CUSTOMER REFERENCE:</b>	Dr Clark Hyland – Forsyth Barr Stairs
<b>TEST SPECIFICATION:</b>	AS/NZS 4671:2001, Clause 7.2.2 (Tensile properties) Steel reinforcing materials  AS 1391-2007 Metallic materials – Tensile testing at ambient temperature
<b>ITEM TESTED:</b>	Three (3) D12 reinforcing bar samples, (Transverse) Three (3) D20 reinforcing bar samples, (Longitudinal)
<b>DATE OF TEST:</b>	17 March 2011
<b>RESULTS:</b>	Refer to the body of this report.  The attention of the client is drawn to the statement of test policy annexed to this report, which form part of the terms of engagement between SAI Global (NZ) limited and the client.
<b>Tested By:</b> W P Morris	<b>Checked By:</b> A L Carson
	
	
<small>This Laboratory is registered by the Testing Laboratory Registration Council of New Zealand. The tests reported herein have been performed in accordance with its terms of registration. This report may not be reproduced except in full. Laboratory Registration Number: 197</small>	
<small>SAI Global (NZ) Ltd 52 Hayton Road P O Box 6178 Christchurch 8442 New Zealand Tel: +64 3 961 6090</small>	
<small>Imtest Group of Laboratories, part of SAI Global</small>	



Date of Issue: 23 March 2011  
Reference: P5673  
Page 2 of 3 Pages

**Results of testing the mechanical properties of steel reinforcing to AS/NZS 4671:2001, Appendix C, Requirements for determining the mechanical and geometric properties of reinforcement**

**Synopsis**

Various sizes of deformed reinforcing steel were supplied for testing to AS/NZS 4671:2001, Appendix C, Requirements for determining the mechanical (see table1) and geometric properties (see table 2) of reinforcement.

Tensile tests were performed in accordance with AS1391 and uniform elongation measurements in accordance with ISO 15630-1.

The nominal bar diameters were used for all calculations.

**C2 MECHANICAL PROPERTIES**

**C2.1 General**

Tests for the determination of the mechanical properties of reinforcement shall be carried out at ambient temperatures in the range 10°C to 35°C.

The condition of test pieces at the time of testing shall be in accordance with Clause 7.2.1 and Table 3.

Unless otherwise specified, tests on bars and coils shall be carried out on straight test specimens of full cross-section having no machining within the gauge length.

Test specimens cut from mesh shall include at least one welded intersection. Before testing a twin-bar specimen, the bar not under test shall be removed with damage to the bar to be tested.

**C2.2 Tensile properties**

**C2.2.1 Equipment**

Tensile testing equipment shall be Grade A as defined in AS 2193.

**C2.2.2 Uniform elongation**

The uniform elongation ( $A_{gt}$ ) shall be determined in accordance with ISO 15630-1 or ISO 15630-2 as appropriate except as in the following cases:

(a) All classes of steels – from extensometer measurements at maximum force taken during tensioning; or

(b) Class E and Class N steels only – from measurements taken after failure.

For the purpose of Item (a), a minimum extensometer gauge length of 50 mm may be used.

For the purpose of Item (b), gauge marks of up to 25 mm intervals may be used.

In the event of a dispute, the extensometer method shall take precedence, unless otherwise agreed between the parties concerned.

**C3 GEOMETRIC PROPERTIES**

**C3.1 Rib geometry**

**C3.1.1 Height of transverse ribs**

The height of transverse ribs (h) shall be measured for each row of ribs at the point where the rib height is greatest. The measurement shall be reported to an accuracy of 0.01 mm.

**C3.1.2 Circumferential spacing of transverse ribs**

The sum of the circumferential gaps (g) between adjacent rows of transverse ribs shall be measured at each of three separate cross-sections and the mean value of the sum calculated. The measurement shall be reported to an accuracy of 0.1 mm.

G:\Common\Keys Documents\IP-Test\IP5673-Hyland Consultants Ltd\Forsyth Barr.docx

## FORSYTH BARR BUILDING STAIRS SITE EXAMINATION AND MATERIALS TEST

## APPENDIX B - REINFORCING STEEL TEST RESULTS

continued

Date of Issue: 23 March 2011  
Reference: P5673  
Page 3 of 3 Pages

**C3.1.3 Longitudinal spacing of transverse ribs**

The spacing of the transverse ribs (c) shall be taken as the length of the measuring distance divided by the number of the rib gaps contained within that length. The measuring distance is deemed to be the interval between the centre-line of a rib and the centre-line of another rib on the same side of the product, determined in a straight line parallel to the longitudinal axis of the product. The length of the measuring distance shall contain at least 10 rib gaps.

**C3.1.4 Calculation of the specific projected rib area ( $f_R$ )**

The specific projected rib area ( $f_R$ ) shall be calculated from the following equation, and with reference to Figure C1:

**Test Results****Mechanical Properties**

Sample Identification	Size	Measured diameter	Elongation at Maximum Force Agt (%)	Yield Stress Re,*Rp0.2 (MPa)	Ultimate Tensile Stress Rm, (MPa)	Ratio Rm/Re
Transverse a	D12	11.33	20.4	325	455	1.40
Transverse b	D12	11.34	23.4	328	442	1.35
Transverse c	D12	11.28	22.0	329	448	1.36
Longitudinal a	D20	18.79	26.5	330	458	1.39
Longitudinal b	D20	18.75	23.5	321	452	1.41
Longitudinal c	D20	18.76	24.2	323	453	1.40

Table 1

**Geometric Properties (Not IANZ accredited)**

Sample Identification	Size	Rib Height (h) (mm)		Circumferential gap (g) (mm)	Longitudinal Pitch (c) (mm)	Specific Projected Area $f_R$
Transverse a	D12	0.70	0.69	0	7.9	0.09
Transverse b	D12	0.78	0.75	0	7.9	0.10
Transverse c	D12	0.82	0.76	0	7.8	0.10
Longitudinal a	D20	1.31	1.17	0	13.2	0.09
Longitudinal b	D20	1.24	1.05	0	13.2	0.09
Longitudinal c	D20	1.25	1.11	0	13.2	0.09

Table 2

Q:\Common\Keys Documents\P-Test\P5673-Hyland Consultants Ltd Forsyth Barr.docx





Annexed to SAI Global (NZ) Ltd Report Number P5673  
Page 1 of 1

### SAI GLOBAL (NZ) LIMITED

#### STATEMENT OF TEST REPORT POLICY

- 1 This report and all incidental work is provided by SAI Global (NZ) Ltd ("SAI") solely for the use of the client employing SAI and SAI does not accept any responsibility to any third party for any reason whatsoever including breach of contract, negligence, negligent mis-statement or wilful act or omission of SAI or any other person arising out of the provision of the report and any person other than the client who uses or relies upon the report does so at his or her own risk.
- 2 The purpose of this report is limited to the compilation of test results only and for no other purpose.
- 3 This report relates only to results obtained from tests performed on the sample of product submitted by the client and SAI accepts responsibility to the client for the performance capabilities of the items actually tested and not for the performance of any other items whether of the same batch, class or general description or not.
- 4 SAI contracts out of the provisions of the Consumer Guarantees Act where a report is supplied to a client for commercial purposes.
- 5 SAI reserves all copyright and intellectual property rights in respect of the report and the report cannot either in whole or in part be included in any circular, written statement or published document whatsoever without SAI's prior approval in writing.
- 6 This report may not be used or referred to in any advertising or product marketing unless SAI has first approved the form of such advertising or marketing in writing.
- 7 Any opinions noted in this report do not constitute part of the report, and are not part of the service paid for and are given for information purposes only. SAI does not accept liability to any party what so ever, including the client, for any statement in any opinion.

SAI Global (NZ) Ltd 52 Hayton Road P O Box 6178 Christchurch 8442 New Zealand Tel: +64 3 961 6090  
Imtest Group of Laboratories, part of SAI Global







FORSYTH BARR BUILDING STAIRS SITE EXAMINATION AND MATERIALS TESTS

## APPENDIX C - DRILLED CONCRETE CORE TEST RESULTS

(Reproduced with permission)

CONCRETE COMPRESSION OF CORES TEST REPORT			
Project :	Material Strength Investigation		
Location :	Forsyth Barr Building, Christchurch		
Client :	Hyland Fatigue & Earthquake Engineering Limited		
Contractor :	Concut Limited		
Sampled by :	Concut Limited (John)		
Date sampled :	15 March 2011		
Sampling method :	Concrete Hole Saw		
Sample description :	Drilled Concrete Core		
Sample condition :	Damp as received		
Date cored :	15 March 2011		
Source of concrete :	Forsyth Barr, Stair Riser (Horizontal core)		
Grade of concrete :	Not Advised		
Design strength :	Not Advised		
Actual slump :	Not Advised		
Date laid :	1988		
		Project No :	6-HFEE.11/006LC
		Lab Ref No :	5672
		Client Ref No :	Clark Hyland
<b>Test Results</b>			
Lab reference no	054	054	054
Client reference no	FB Stairs 1	FB Stairs 2	FB Stairs 3
Date tested	28/03/11	28/03/11	28/03/11
Dry cured (days)	7	7	7
Size & position of any reinforcement	No Steel	No Steel	No Steel
Visual description	Horizontal Core	Horizontal Core	Horizontal Core
Average core diameter (mm)	91.9	92.6	92.0
Average core length (mm)	180.1	195.5	188.4
Density (kg/m <sup>3</sup> )	2368	2404	2406
Height diameter ratio	1.96	2.11	2.05
Conditioning	Dry	Dry	Dry
Load at failure (kN)	284.7	337.2	310.5
Compressive strength (MPa)	43.0	50.0	46.5
Type of fracture	Cone/Shear	Cone/Split	Cone/Split
<b>Test Methods</b>		<b>Notes</b>	
Testing of Cores, NZS 3112 : Part 2 : 1986, Clause 9		Sampling is outside the laboratory's scope of accreditation	
Compression, NZS 3112 : Part 2 : 1986, Clause 6			
Density, NZS 3112 : Part 3 : 1986, Clause 5			
Capping, NZS 3112 : Part 2 : 1986, Clause 4 (amendment No.2 2000)			
Date tested :	28 March 2011	Sampling is not covered by IANZ Accreditation. Results apply only to sample tested.	
Date reported :	29 March 2011	This report may only be reproduced in full	
IANZ Approved Signatory		 Tests indicated as not accredited are outside the scope of the laboratory's accreditation	
Designation :	Laboratory Manager		
Date :	29 March 2011		
PF-LAB-095 (18/12/2010)	Opus International Consultants Limited Christchurch Laboratory	52C Hayton Road Wigram, Christchurch 8042, New Zealand	Page 1 of 1 Telephone +64 3 343 0739 Facsimile +64 3 343 0737 Website www.opus.co.nz
Quality Management Systems Certified to ISO 9001			



FORSYTH BARR BUILDING STAIRS SITE EXAMINATION AND MATERIALS TESTS

## APPENDIX D – STAIR SEISMIC GAP MORTAR TEST RESULTS

(Reproduced with permission)

CONCRETE COMPRESSION OF CORES TEST REPORT	
Project :	Quality Assurance Assessment
Location :	Forsyth Barr Building
Client :	Hyland Fatigue & Earthquake Engineering
Contractor :	Clark Hyland
Sampled by :	Clark Hyland
Date sampled :	21 March 2011
Sampling method :	Site Removal
Sample description :	Seismic Stairway Grout Strip
Sample condition :	Dry as received
Date recovered :	21 March 2011



Project No :	6-JHFEE.11/6LC
Lab Ref No :	5708
Client Ref No :	Clark Hyland

Test Results				
Lab reference no		074		
Client reference		#1	#2	#3
Date tested		23 March 2011		
Age (Days)		Not Applicable		
Size & position of any reinforcement		Not Applicable		
Visual description		Grout Strip & 3mm Laminate		
Dimension # one (mm)		10.9	16.6	17.5
Dimension # two (mm)		31.1	32.2	33.7
Cross Sectional Area (mm <sup>2</sup> )		339	534	590
Mass of section in air (g)		36	70	79
Density (kg/m <sup>3</sup> )		2000	1902	1946
Conditioning		Compressed as received		
Load at failure (kN)		7.12	10.2	12.5
Compressive strength (MPa)		21.0	19.1	21.1
Type of fracture		Columnar	Columnar	Columnar

Test Methods	Notes
Testing of Cores, NZS 3112 : Part 2 : 1986, Clause 9 Compression, NZS 3112 : Part 2 : 1986, Clause 6 Density, NZS 3112 : Part 3 : 1986, Clause 5	Docking of grout to achieve sections not IANZ accredited

Date tested : 22 March 2011  
Date reported : 23 March 2011

Testing is covered by IANZ Accreditation  
This report may only be reproduced in full

IANZ Approved Signatory 

Designation : Laboratory Manager  
Date : 23 March 2011



Tests indicated as not accredited are outside the scope of the laboratory's accreditation

CSF 2095 (13/09/2006)

Opus International Consultants Limited  
Christchurch Laboratory  
Quality Management Systems Certified to ISO 9001

52C Hayton Road  
Wigram, Christchurch 8042,  
New Zealand

Telephone +64 3 343 0739  
Facsimile +64 3 343 0737  
Website www.opus.co.nz

Page 1 of 1



## FORSYTH BARR BUILDING STAIRS SITE EXAMINATION AND MATERIALS TESTS

## APPENDIX E – LAYOUT DRAWINGS

Disclaimer:

Layouts and details shown in Figure 35 to Figure 37 are based on the Drawings held by the Council and do not necessarily accurately reflect the as-built condition

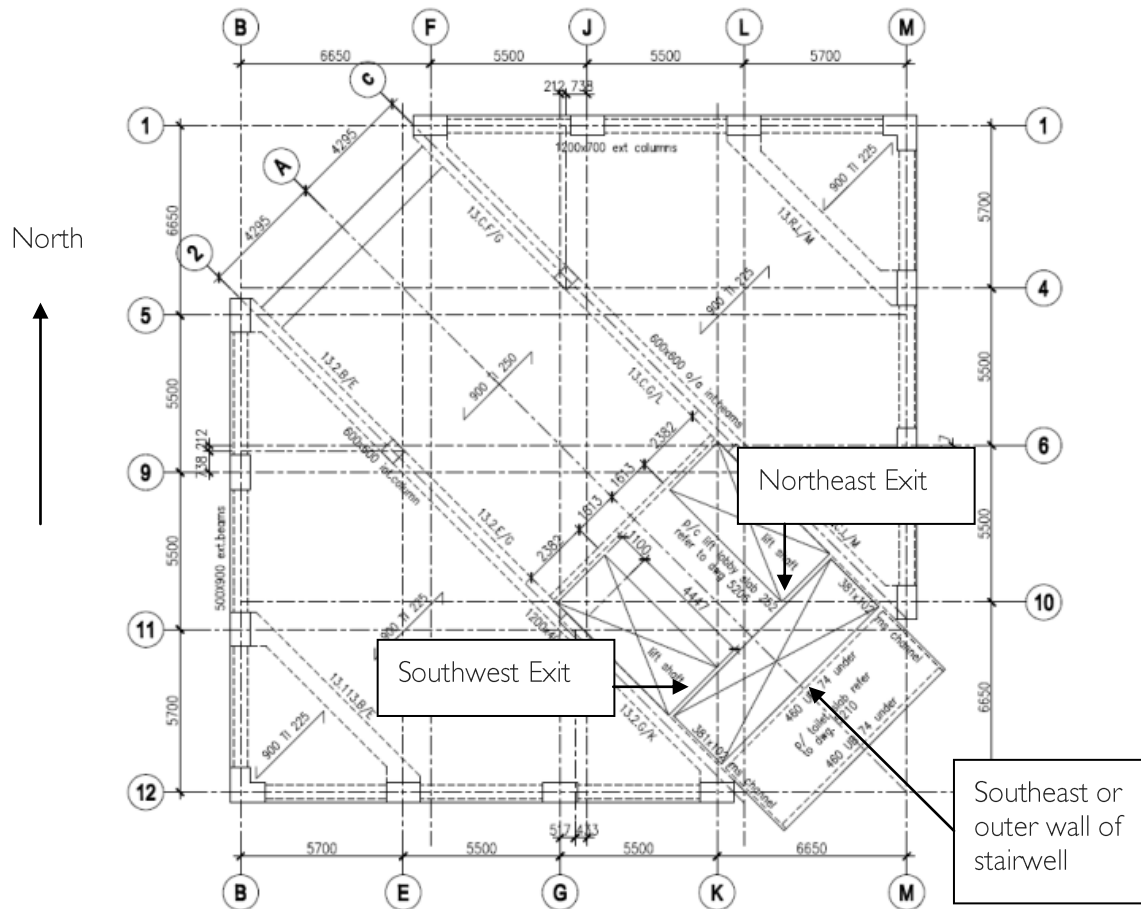

Figure 35 – Typical floor layout and stairwell orientation

FORSYTH BARR BUILDING STAIRS SITE EXAMINATION AND MATERIALS TEST

APPENDIX E – LAYOUT DRAWINGS

continued

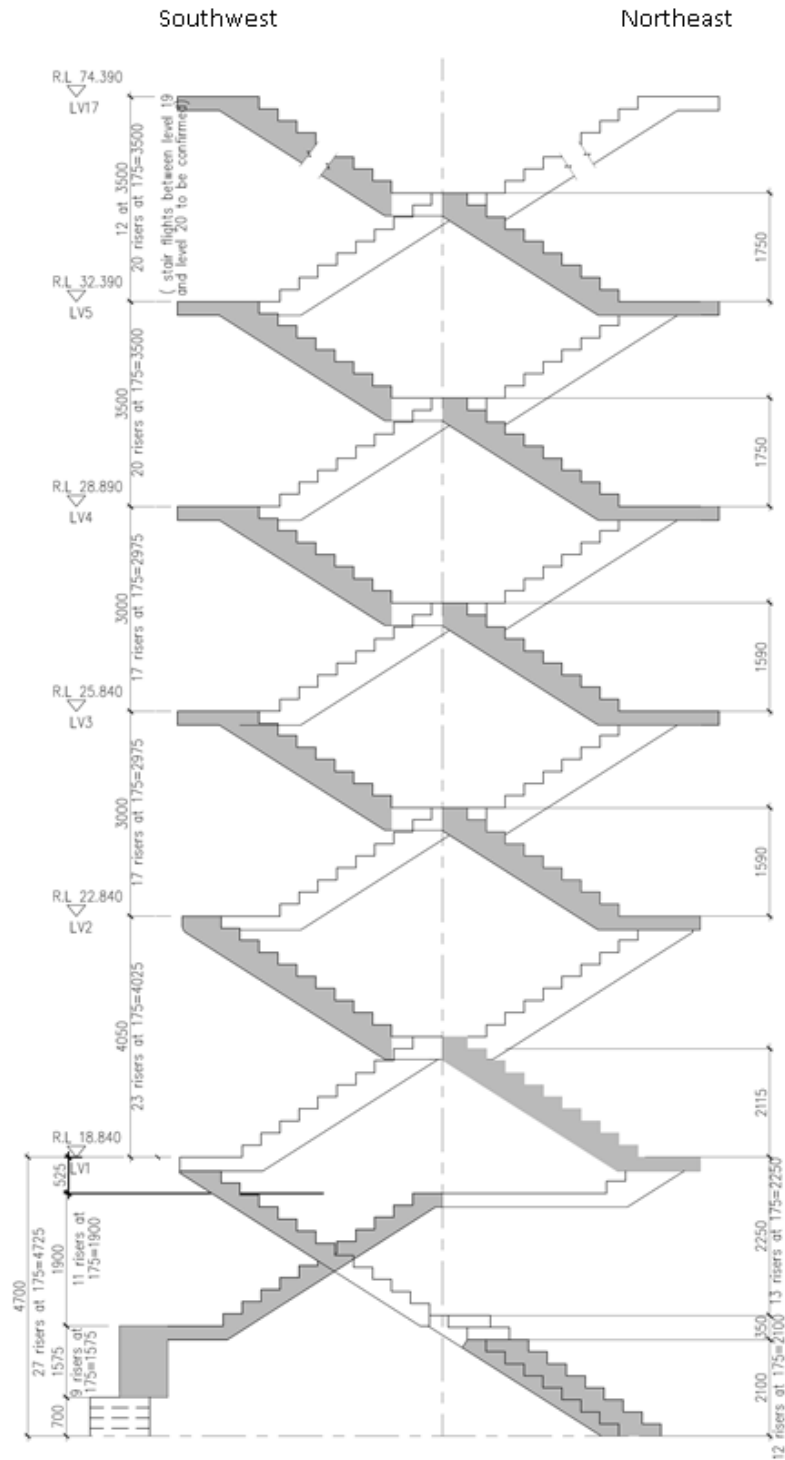

Figure 36 – Stair Elevation



FORSYTH BARR BUILDING STAIRS SITE EXAMINATION AND MATERIALS TEST

APPENDIX E – LAYOUT DRAWINGS

continued

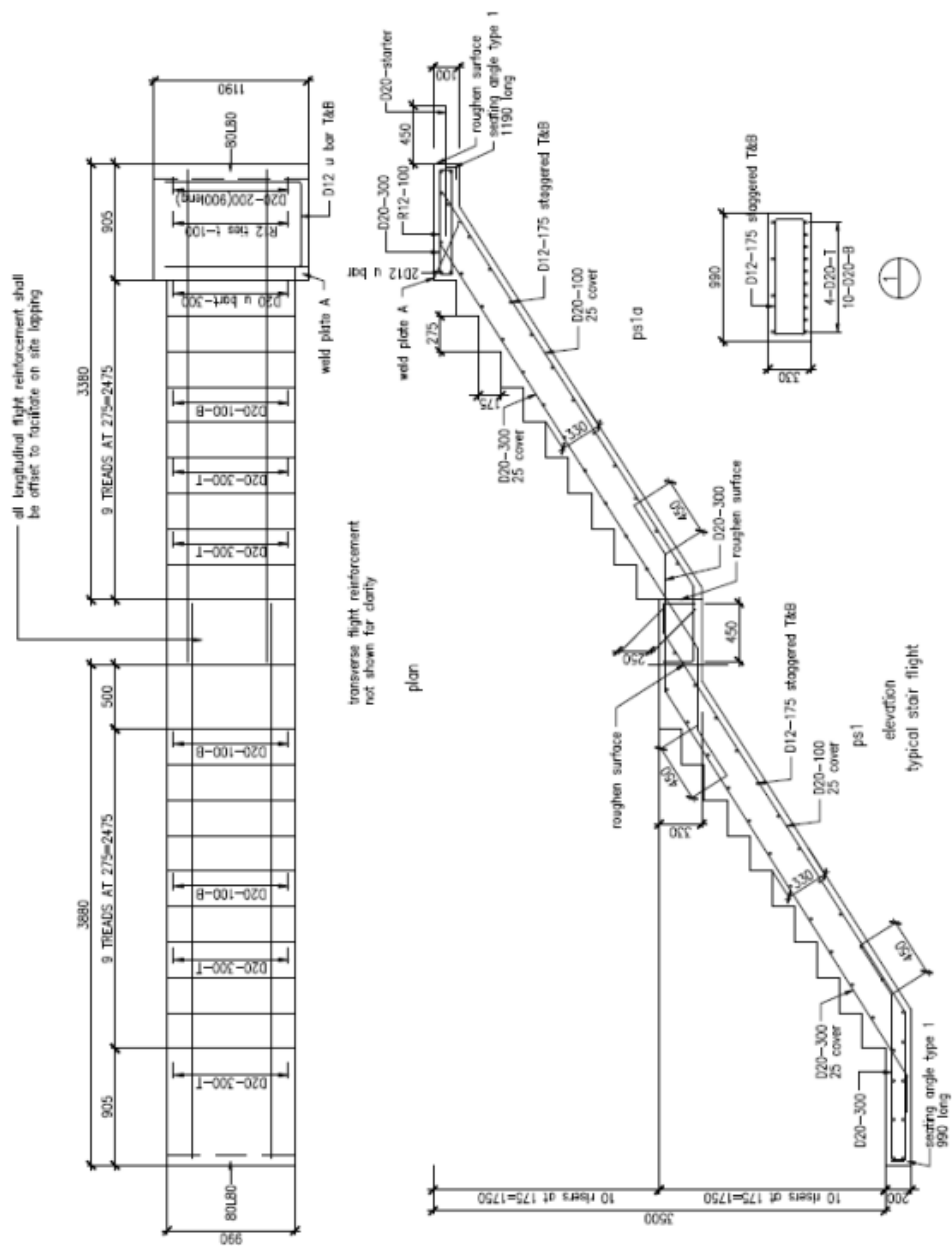

Figure 37 – Typical stair details

FORSYTH BARR BUILDING STAIRS SITE EXAMINATION AND MATERIALS TEST

APPENDIX E – LAYOUT DRAWINGS

continued

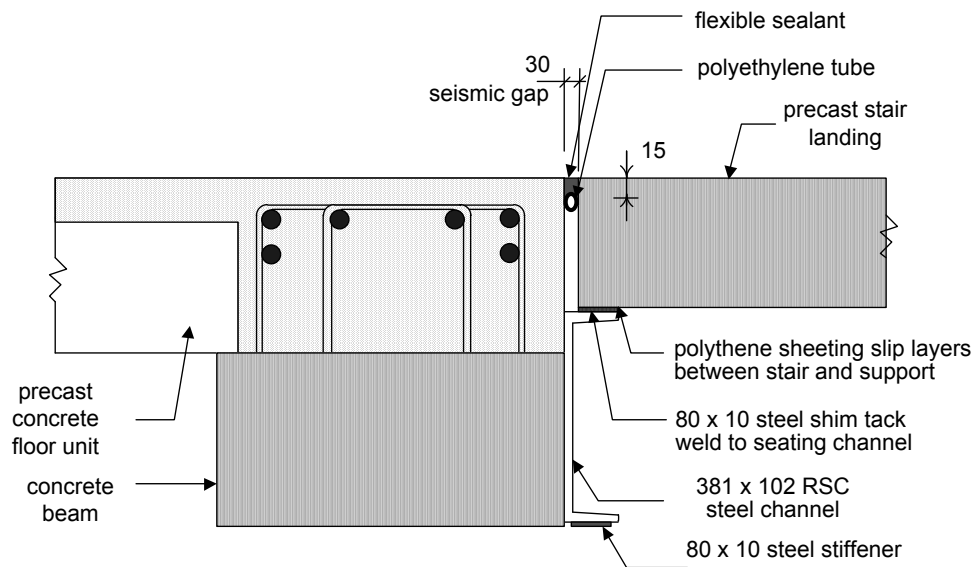

Figure 38 - Typical lower landing detail with seismic joint.

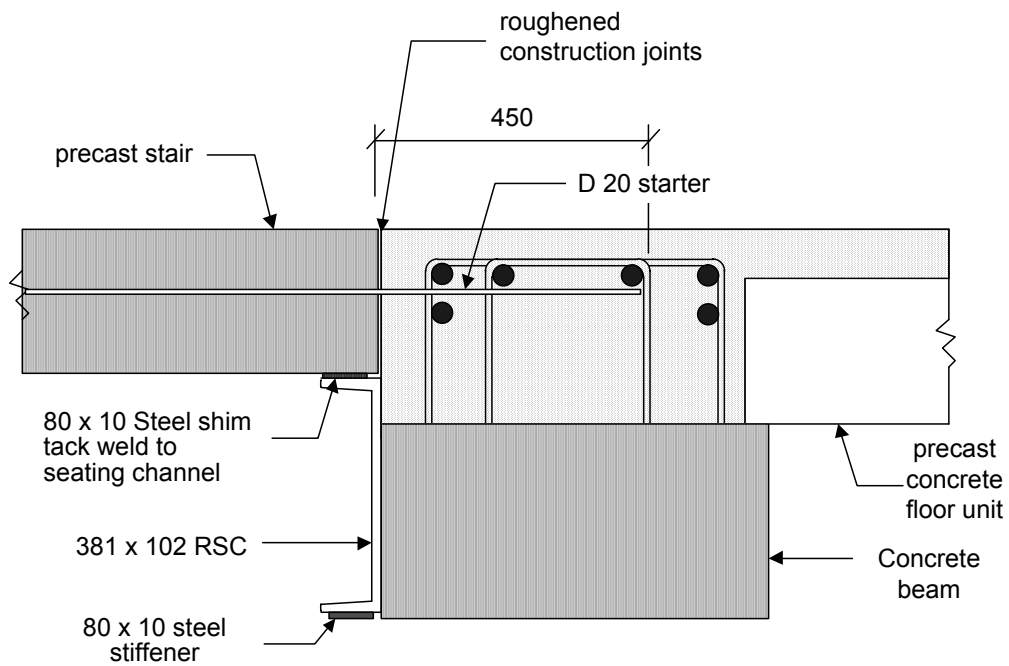

Figure 39 - Typical upper landing support detail.