

SECTION B

**THE ANALYSIS AND DESIGN OF AND THE EVALUATION
OF DESIGN ACTIONS FOR REINFORCED CONCRETE DUCTILE SHEAR WALL STRUCTURES**

T. Paulay* and R.L. Williams**

ABSTRACT:

A comprehensive review of the state of the art in the design of earthquake resisting ductile structural walls is presented. The material has been compiled from the technical literature, the deliberations within the New Zealand National Society for Earthquake Engineering and research efforts at the University of Canterbury. The paper attempts a classification of structural types and elaborates on the hierarchy in energy dissipation. After a review of available analysis procedures, including modelling assumptions, a detailed description of capacity design procedures for both cantilever and coupled shear wall structures is given. The primary purpose of capacity design is to evaluate the critical design actions which can be used in the proportioning and reinforcing of wall sections which can be used in the proportioning and reinforcing of wall sections. An approach to the estimation of structural deformation is suggested. To satisfy the ductility demands imposed by the largest expected earthquake, detailed design and detailing recommendations are given and the application of some of these is presented in an appendix.

INTRODUCTION:

The usefulness of structural walls in the planning of multistorey buildings has long been recognized. When walls are situated in advantageous positions in a building, they can become very efficient in lateral load resistance, while also fulfilling other functional requirements.

Because a large portion of the lateral load on a building, if not the whole amount, and the horizontal shear force resulting from it, are often assigned to such structural elements, they have been called shear walls. The name is unfortunate because shear should not be the critical parameter of behaviour.

The basic criteria that the designer will aim to satisfy when using structural walls in earthquake resistant structures are as follows:

- (a) To provide adequate stiffness so that during moderate seismic disturbances complete protection against damage, particularly in non-structural components, is assured.
- (b) To provide adequate strength to ensure that an elastic seismic response, generating forces of the order specified by building codes⁽¹⁾, does not result in more than superficial structural damage. Even though during such an event some non-structural damage is expected, it is unlikely that in buildings with well designed shear walls this will be serious.
- (c) To provide adequate structural ductility and capability to dissipate energy for the case when the largest disturbance to be expected in the region does occur. Extensive damage, perhaps beyond the possibility of repair, is accepted

under these extreme conditions, but collapse must be prevented.

- (d) The subsequent sections concentrate on those aspects of the design and response of structural walls that are relevant to this third design criterion. Consequently the inelastic response of structural walls, when subjected to simulated cyclic reversed loading, together with various parameters that must affect this response, will be examined in some detail for various types of structures. It will be assumed that in all cases adequate foundations can be provided so that rocking will not occur and that energy dissipation, when required, will take place in the structural wall above foundation level. A detailed discussion of concepts, relevant to the design of foundations for shear wall structures, is provided in Reference 5. Also it will be assumed that:
 - (i) Inertia forces at each floor can be introduced to the structural wall by adequate connections, such as collector beams or diaphragms and from the floor system, and that
 - (ii) The foundation for each wall does not significantly affect its stiffness relative to similar other walls in a building.

TYPES OF DUCTILE STRUCTURAL WALLS:

In this section the principles of the analyses and the design of earthquake resisting structural walls, in which significant amounts of energy can be dissipated by flexural yielding in the superstructure, are examined. The prerequisite in the design of such seismic walls is that flexural yielding in clearly defined plastic hinge zones must control the strength to be utilized during imposed inelastic seismic displacements. As a

* Professor of Civil Engineering, University of Canterbury, Christchurch

** District Structural Engineer, Ministry of Works & Development, Hamilton

corollary to this requirement, failure due to shear, inadequate anchorage or splicing of the reinforcement, instability of concrete components or compression bars and sliding along construction joints must be avoided, while large inelastic seismic displacements are sustained by the structure. Some of the failure modes mentioned are illustrated in figure 1.

In the evaluation of the equivalent lateral static design load, to be used in establishing the minimum seismic strength of a structure, the New Zealand Design and Loading Code⁽¹⁾ specifies structural type factors, S . These factors are intended to reflect the expected seismic performance of the structure. There are two aspects which are to be considered in the assessment of performance, one is the ability of the type of structure to dissipate energy in a number of inelastic displacement cycles, and the other is the degree of redundancy existing in the chosen structural system. A high degree of structural redundancy, involving a large number of localities where energy dissipation by flexural yielding can occur, is desirable.

Accordingly it is recommended that earthquake resisting ductile structural walls be classified as follows:

- (a) Two or more cantilever walls with a height, h_w , to horizontal length, l_w , ratio of not less than two are assigned a structural type factor of $S = 1.0$ (see figure 2a).
- (b) For two or more cantilever walls, each with an aspect ratio h_w/l_w not less than two, which are coupled by a number of appropriately reinforced ductile coupling beams that are capable of dissipating a significant portion of the seismic energy, the value of S is 0.8. This is in recognition of the high degree of redundancy and the fact that damage is likely to be small in the gravity load carrying elements.

The significance of the coupling beams in energy dissipation is conveniently expressed by the contribution of the coupling beams to the total overturning moment that is produced by the code specified lateral loading at the base of the coupled shear wall structure. This is illustrated in figure 17. A suitable parameter which expresses this is the moment ratio

$$A = \frac{Tl}{M_0} \quad (B-1)$$

where T = induced axial load in one of the two coupled shear walls at the base of the structure due to the code specified lateral static loading

l = distance between axes of the two walls

M_0 = overturning moment due to the

load inducing T , about the base of the structure

These quantities may be seen in figure 17.

Depending on the contribution of the beams to the resistance of overturning moment and hence to total energy dissipation, the structural type factor, S , is made dependent on the moment ratio, A , thus

$$\text{when } 0.67 \geq A \geq 0.33 \quad (B-2)$$

$$\text{then } 0.8 \leq S = 0.8 + 0.6 \times (0.67 - A) \leq 1.0 \quad (B-3)$$

For intermediate values of A a linear interpolation of S may be made. The application of this is discussed in detail in section B.5.3.4.

Typically for a wall with deep coupling beams, illustrated in figure 17b, the appropriate S factor is likely to be 0.8. When walls are interconnected by slabs only, (figure 17c) as is often the case in apartment buildings, the value of A from Eq. (B-1) will usually be much less than 0.33 and hence $S = 1.0$. A comparison of the moment contribution of the lT component to the total overturning moment M_0 is shown in figure 18.

- (c) Single cantilever walls, with $h_w/l_w > 2$, are to be designed with $S = 1.2$, to compensate for the lack of redundancy. (See figure 2b).
- (d) Squat cantilever walls with an aspect ratio of $h_w/l_w < 2$, in which shear effects are likely to be dominant, are not expected to produce as efficient energy dissipation due to flexural ductility as more slender structural walls. Shear deformations, particularly shear sliding, may cause significant pinching in the hysteresis loops exhibited by squat shear walls⁽²⁾, and thereby loss of energy dissipation will occur.

In order to reduce the displacement ductility demand on squat walls, the strength of the walls with respect to seismic loading should be increased. Hence for walls for which $1 \leq h_w/l_w \leq 2$, the structural type factor given above in (a), (b) and (c) should be multiplied by Z where

$$1 \leq Z = 2.2 - 0.6 h_w/l_w \leq 1.6 \quad (B-4)$$

It is to be noted that the use of higher structural type factors, i.e. $S = 1.6 \times 1.0 = 1.6$ or $S = 1.6 \times 1.2 = 1.92$, is expected only to reduce but not to eliminate the ductility demand on squat shear walls.

Squat walls will have a relatively low fundamental period ($T < 0.6$ sec). It is known that short period structures, designed to the requirements of the New Zealand loading code⁽¹⁾, are likely to be subjected to higher ductility demands than long period structures.

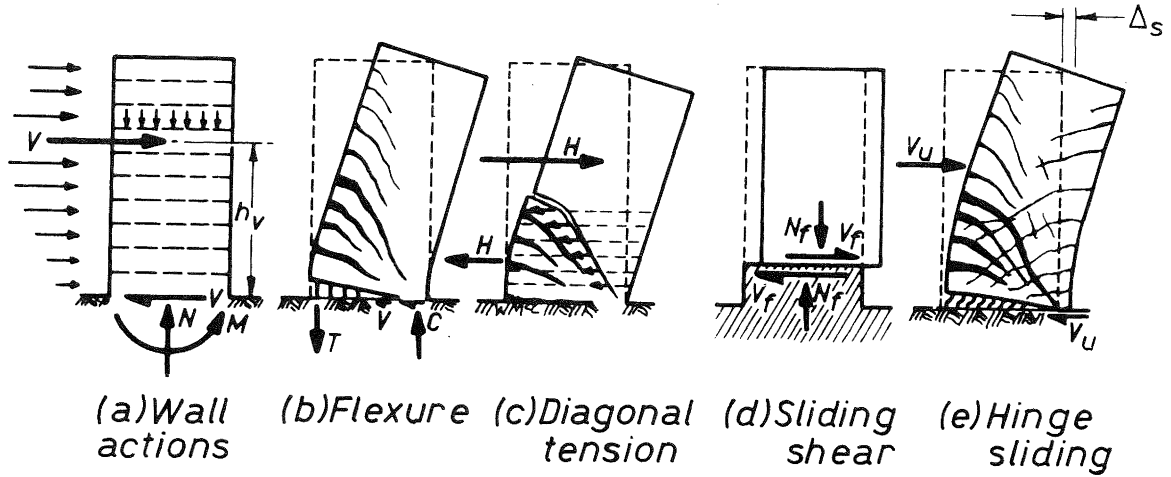

Fig. 1 - Possible Failure Modes in Cantilever Shear Walls

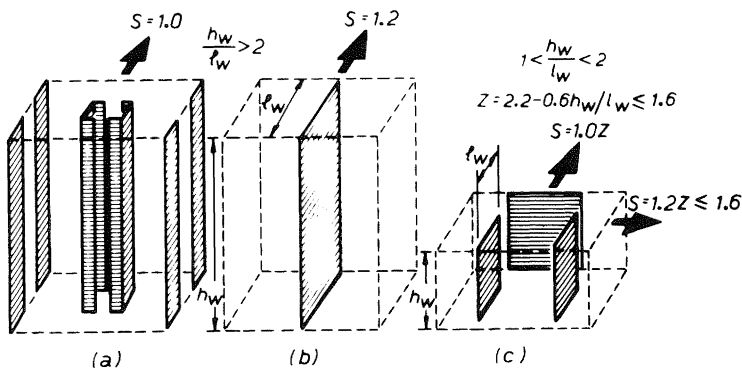

Fig. 2 - Types of Cantilever Shear Walls with Appropriate S Factors

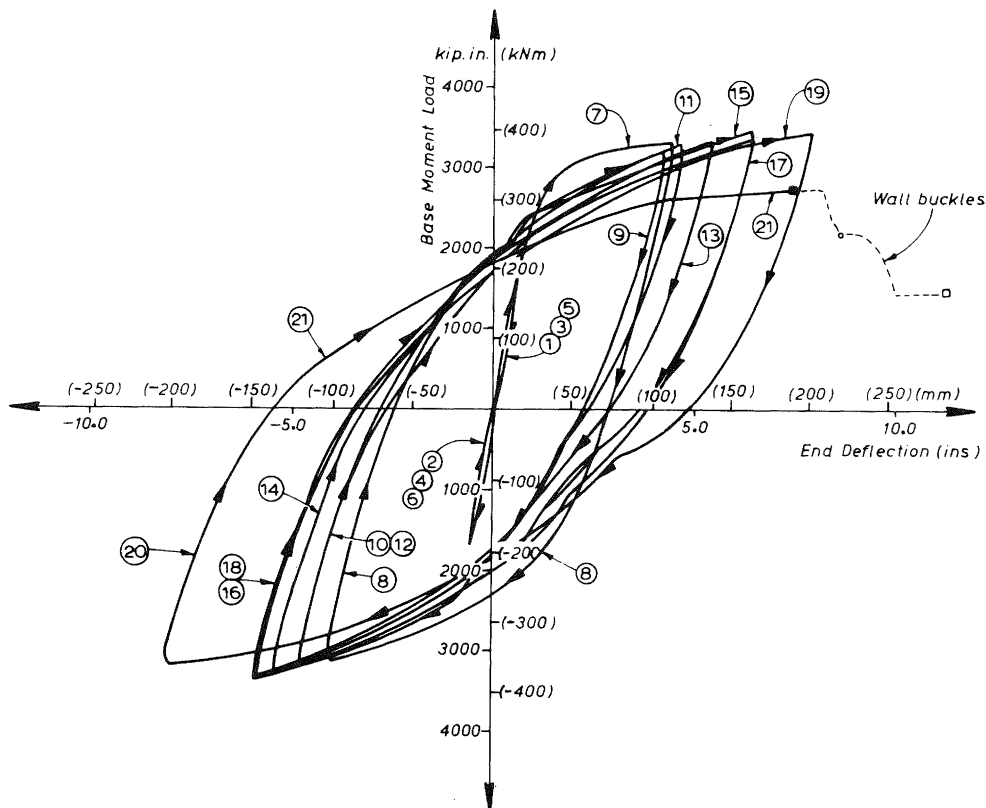

Fig. 3 - Load-Displacement Response to Cyclic Reversed Loading of a Ductile Shear Wall Structure (10)

Moreover, in a given earthquake, a short period squat shear wall is likely to be subjected to a greater number of excursions beyond yield than a long period structure. Therefore the cumulative ductility, which has some relevance to damage, is still high. These observations indicate that squat shear walls, such as shown in figure 2c, designed with a modified structural type factor, S , must also be ductile and hence they must be detailed accordingly.

Structural walls of different types are reviewed in Reference 3 and detailed procedures recommended for walls which cannot be made fully ductile are presented in Reference 4. The requirements for the design of foundations which can sustain inelastic superstructures when their maximum feasible seismic strength is being developed, are examined in Reference 5.

HIERARCHY IN ENERGY DISSIPATION:

It is generally accepted that for most situations energy dissipation by hysteretic damping is a viable means by which structural survival of large earthquake imposed displacements can be assured. This may involve very large excursions beyond yield. Such structures must therefore be ductile. To ensure the desired energy dissipation, the designer's primary aim will be to minimize the inevitable degradation in both stiffness and strength.

Flexural Yielding of Ductile Walls

An obvious source of hysteretic damping is the yielding of the principal flexural reinforcement. Yielding can be restricted to well defined plastic hinge zones, as shown in figure 1b. Therefore such areas deserve special attention. Concrete, being a relatively brittle material that shows rapid strength degradation, in both compression and shear, when subjected to repeated inelastic strains and multi-directional cracking, should not be considered in structural walls as a significant source of energy dissipation. To ensure the desired ductility, the major part of the internal forces in the potential plastic region of a shear wall should therefore be allocated to reinforcement. The desired response of a ductile shear wall structure manifests itself in well rounded load-displacement hysteresis loops, such as shown in figure 3.

Control of Shear Distortions

While shear resisting mechanisms in reinforced concrete, that rely on the traditional truss mechanism (figure 1c), can be made relatively ductile in shear during monotonic loading, they are generally unsuitable for inelastic cyclic shear loading. Shear resistance after inelastic shear displacements can be attained only when the subsequent imposed displacement is larger than the largest previously encountered displacement. Inelastic tensile strains in stirrup reinforcement can never be recovered and hence in such

cases the width of diagonal cracks also increases with progressive cyclic loading. Curves 3 and 4 in figure 4 show typical load displacement responses for one quadrant of a displacement cycle, which have been affected by significant shear displacements. In comparison curves 1 and 2 show the idealized elastic-plastic and the optimal response of a reinforced concrete member. In order to minimize the 'pinching' of hysteresis loops, i.e. the loss of energy dissipating capacity within restricted displacements, designers should endeavour to suppress inelastic shear distortions. In conventionally reinforced walls the detrimental effect of shear increases with the magnitude of the shear stress. For example figure 5 shows the hysteretic response of a cantilever shear wall in which, due to relatively large shear stresses, shear deformations have become increasingly significant with increased cycles of loading and the amplitude of the applied deflection at the top of the wall. It is also seen that in each cycle the stiffness of the wall decreased, even though the full capacity of the wall was attained. The envelope curve follows closely the load-displacement curve that is obtained during monotonic loading with the same displacement ductility. If several cycles with the same magnitude to top displacement are applied, for example to 4 in (10 cm) in each direction, (see figure 5), the load attained would have gradually decreased in each cycle. Such a wall is likely to fulfill the design criteria but its performance is clearly inferior to that demonstrated in figure 4.

The Desired Hierarchy in Strength

From the features considered above it becomes evident that the design procedure must endeavour to minimize the likelihood of a shear failure, even during the largest intensity shaking. This is achieved by evaluating the flexural capacity of a wall from the properties shown on the structural drawings. With proper allowance for various factors, to be examined in "Capacity Design Procedures", the likely maximum of the moment that can be extracted from a shear wall structure during an extreme seismic inelastic displacement can be readily evaluated. The shear force associated with the development of such a moment can then be estimated. This must be done using conservative estimates. Subsequently the wall can be reinforced so as to possess corresponding shear strength.

When the shear strength of a wall is not in excess of the flexural strength, a situation which commonly arises in squat shear walls, not only does stiffness degradation occur but the attainable full capacity of wall will also reduce with cyclic displacements. Such an undesirable response is shown in figure 6.

Similar procedures must be followed to ensure that other undesirable failure modes, such as due to bond and anchorage of the reinforcement or sliding along construction joints, will not occur while the maximum flexural capacity of the wall, usually at its base, is being developed

several times in both directions of the loading.

Capacity design procedures will ensure that the desired hierarchy in the energy dissipating mechanism can develop. The procedure is quantified and discussed in detail in "Capacity Design Procedures".

ANALYSIS PROCEDURES:

Modelling Assumptions

Modelling of member properties -

When, for the purpose of either a static or dynamic elastic analysis, stiffness properties of various elements of reinforced concrete shear wall structures need be evaluated, some approximate allowance for the effects of cracking should be made. In this, it is convenient to assume that reinforced concrete components exhibit properties that are similar to those of elements with identical geometric configurations but made of perfectly elastic, homogeneous and isotropic materials. For the sake of simplicity an approximate allowance for shear and anchorage deformations is also made.

These recommendations for modelling may be considered to lead to acceptable results when the primary purpose of the elastic analysis is the determination of internal structural actions that result from the specified lateral static loading or from dynamic modal responses. The estimates given below are considered to be satisfactory also for the purpose of predicting the fundamental period of the structure and for checking deflections in order to satisfy code specified limits for deflections or separations of non-structural components.

In ductile earthquake resisting structures significant inelastic deformations are expected. Consequently the allocation of internal design actions in accordance with an elastic analysis should be considered as one of several acceptable solutions which satisfy the unviolable requirements of internal and external equilibrium. As will be seen subsequently, deliberate departures in the allocation of design actions from the elastic solutions are not only possible, but they may also be desirable.

When it is necessary to make a realistic estimate of the deformations of an elastic wall system which is subjected to a relatively high intensity loading, the absolute value of the stiffness is required. Rather than specify a stiffness, an equivalent second moment of area of the wall section, I_e , will be defined in order to allow deflections to be estimated for various patterns of loading. The first loading of a wall up to and beyond first cracking is of little interest in design. In this recommendation only deformations of the wall, in which cracks have fully developed during previous cycles of elastic loading, will be considered.

In arriving at the equivalent stiffness of a wall section, flexural deformations of the cracked wall, anchorage deformations at the wall base and shear deformations after the onset of diagonal cracking should be considered. Detailed steps of these approximations are set out in Appendix I.

Deformations of the foundation structure and the supporting ground, such as tilting or sliding, are not considered in this study, as these produce only rigid body displacement for the shear wall superstructure. Such deformations should, however, be taken into account when the period of the structure is being evaluated or when the deformation of a shear wall is related to that of adjacent frames or walls which are supported on independent foundations⁽⁵⁾.

Accordingly, for cantilever shear walls subjected predominantly to flexural deformations, the equivalent second moment of area may be taken as 60% of the value based on the uncracked gross concrete area of the cross section, with the contribution of reinforcement being ignored i.e.

$$I_e = 0.60 I_g \quad (B-5)$$

When elastic coupled shear walls are considered, where, in addition to flexural deformation, extensional distortions due to axial loads are also being considered, the equivalent moment of inertia and area may be estimated as follows:

- (a) For a wall subjected to axial tension

$$I_e = 0.5 I_g \quad (B-6)$$

$$A_e = 0.5 A_g \quad (B-7)$$

- (b) For a wall subjected to compression

$$I_e = 0.8 I_g \quad (B-8)$$

$$A_e = A_g \quad (B-9)$$

- (c) For diagonally reinforced coupling beams

$$I_e = 0.4 I_g \quad (B-10)$$

- (d) For conventionally reinforced coupling beams or coupling slabs

$$I_e = 0.2 I_g \quad (B-11)$$

In the above expressions the subscripts "e" and "g" refer to the "equivalent" and "gross" properties respectively.

When only slabs connect adjacent shear walls, the equivalent width of slab to compute I_e may be taken as the width of the opening between the walls or 8 times the thickness of the slab, whichever is less.

For cantilever walls with aspect ratios, h_w/l_w , larger than 4, the effect of shear deformations upon stiffness may normally be neglected. When a combination of "slender" and "squat" shear walls provide the seismic resistance, the latter may be allocated an

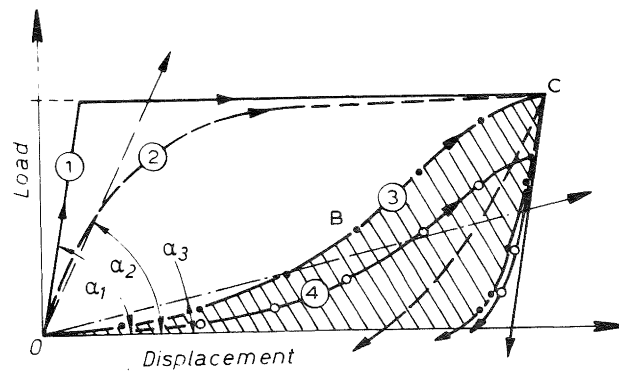

Fig. 4 - Load-Displacement Response for (1) Idealized, (2) Optimal, (3) (4) Repeated Shear Affected Conditions in Reinforced Concrete Members.

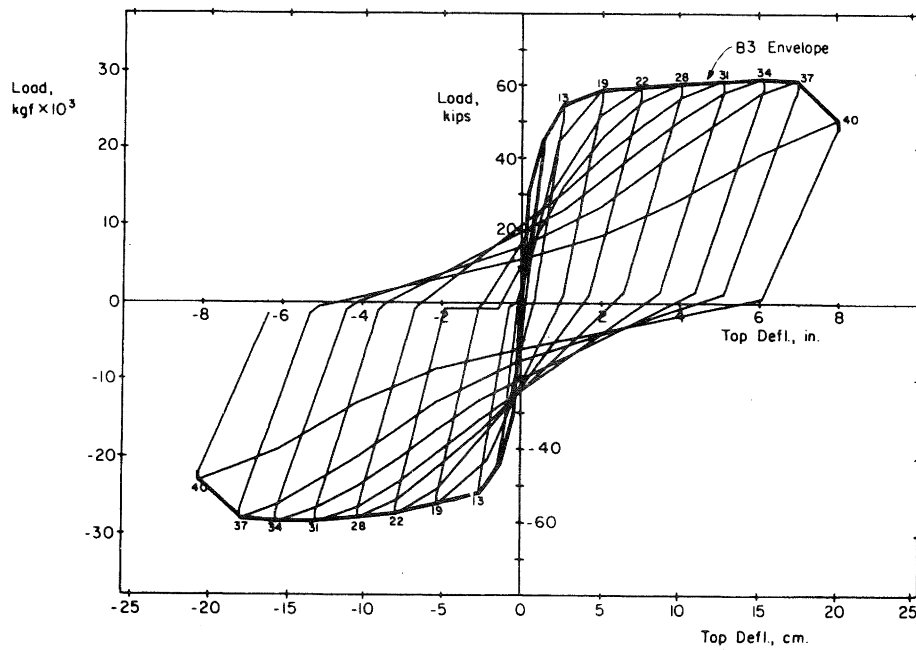

Fig. 5 - The Hysteretic Response of a Cantilever Shear Wall with Significant Shear Deformations (11)

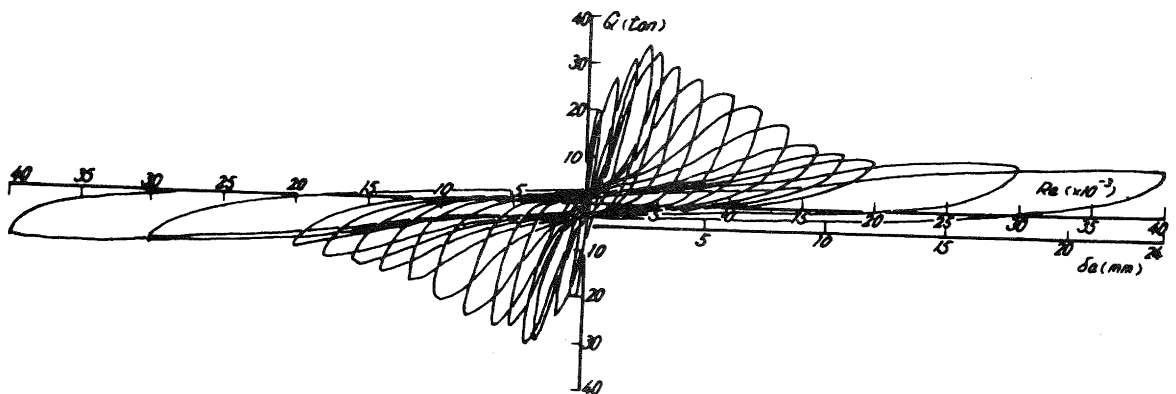
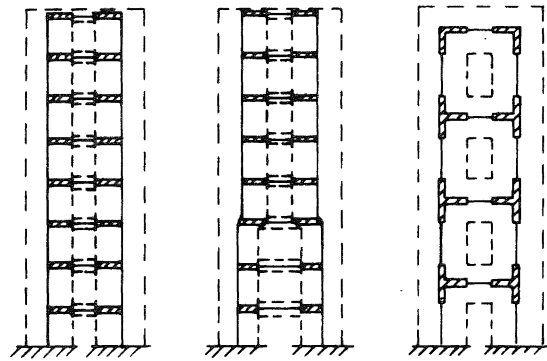

Fig. 6 - The Hysteretic Response of a Shear Wall in which Shear governs the strength.



WIDE COLUMN FRAME (a)

Fig. 7 The Modelling of Coupled Shear Walls for (a) Frame Analysis or (b) Laminar Analysis

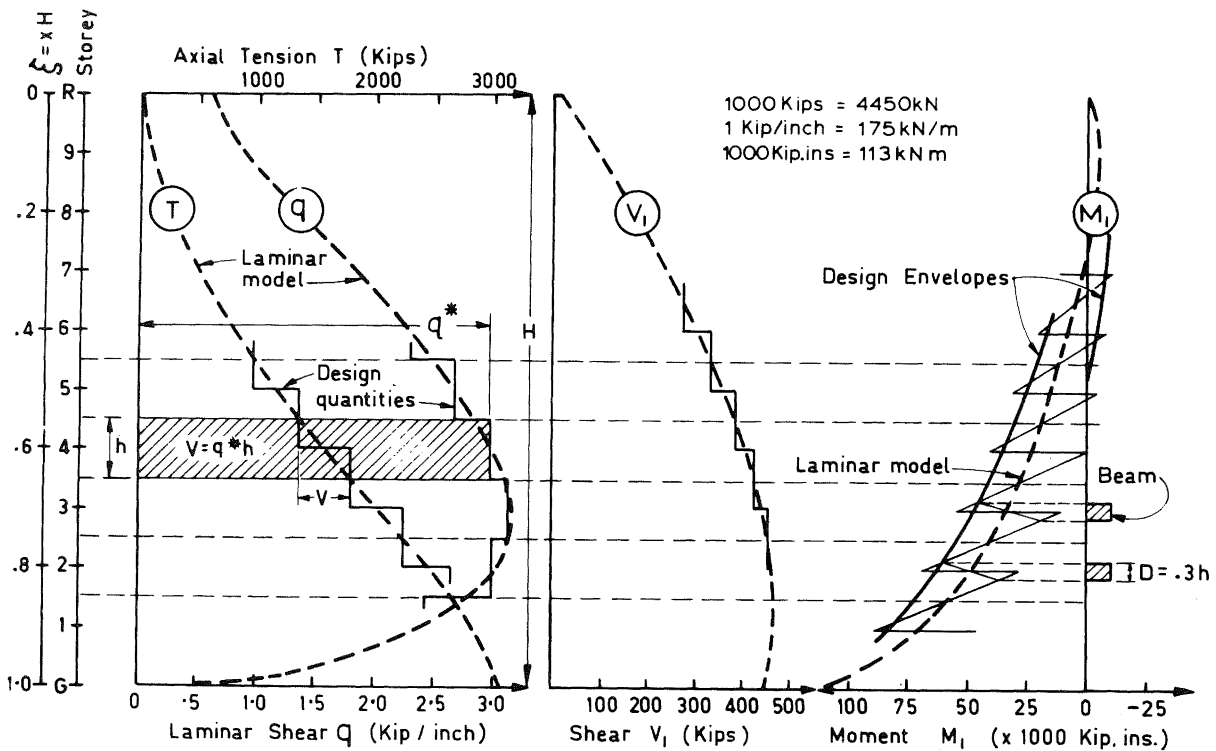
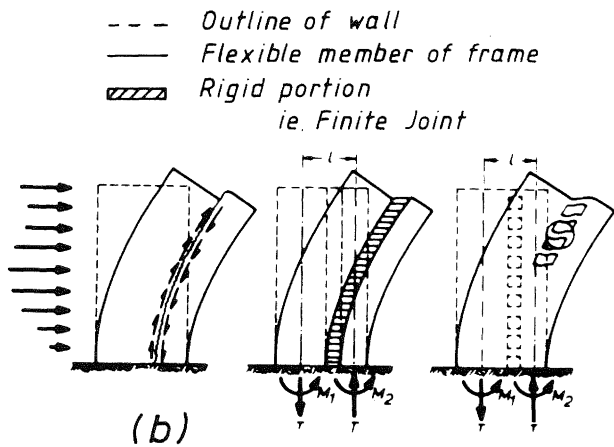

Fig. 8 - The Results of the Laminar Analysis of a Laterally Loaded Coupled Shear Wall Structure.

excessive proportion of the total load if shear distortions are not accounted for. For such cases, i.e. when $h_w/\ell_w < 4$, it may be assumed that

$$I_w = \frac{I_e}{1.2 + F} \quad (B-12)$$

where

$$F = \frac{30 I_e}{h_w^2 b_w \ell_w} \quad (B-13)$$

A more accurate estimate of flexural deformations may be made if the ratio of the moment causing cracking to the maximum applied moment is evaluated and an improved value of I_e is used in Eqs. (B-12) and (B-13) thus

$$I_e = \left(\frac{M_{cr}}{M_a} \right)^3 I_g + \left(1 - \left(\frac{M_{cr}}{M_a} \right)^3 \right) I_{cr} \quad (B-14)$$

- where b_w = web thickness of wall section
 ℓ_w = horizontal length of wall
 h_w = height of wall
 M_{cr} = cracking moment according to Eq. (B-15)
 M_a = maximum moment at which deflection is computed
 I_{cr} = moment of inertia of cracked section transformed to concrete
 $M_{cr} = \frac{f_r I_g}{y_t} \quad (B-15)$
 where f_r = the modulus of rupture of concrete = $0.62 \sqrt{f_c}$ MPa
 y_t = distance from centroidal axis of gross section, neglecting the reinforcement, to extreme fibre in tension
 f_c = specified compressive strength of concrete, MPa
 I_g = second moment of area of the gross concrete section

In Eq. (B-12) some allowance has also been made for shear distortions and deflections due to anchorage (pull-out) deformations at the base of a wall, and therefore these deformations do not need to be calculated separately.

Deflections due to code⁽¹⁾ - specified lateral static loading may be determined with the use of the above equivalent sectional properties. However, for consideration of separation of non-structural components and the checking of drift limitations the appropriate amplification factor given in the code⁽¹⁾, must be used.

Geometric modelling -

For cantilever shear walls it will be sufficient to assume that the sectional properties are concentrated in the vertical centre line of the wall. This should be taken to pass through the centroidal axis of the wall section, consisting of the gross concrete area.

When cantilever walls are interconnected at each floor by a slab it is normally sufficient to assume that the floor will act as a rigid diaphragm. Thereby the positions of walls relative to each other will remain the same during the lateral loading of the shear wall assembly. By neglecting wall shear deformations and those due to torsion and restrained warping of an open wall section, the lateral load analysis can be reduced to that of a set of cantilevers in which flexural distortions only will control the compatibility of deformations. Such analysis, based on first principles, can properly allow for the contribution of each wall when it is subjected to deformations due to floor translations or torsion⁽²⁾. It is to be remembered that such an elastic analysis, however approximate it might be, will satisfy the requirements of static equilibrium, and hence it will lead to a satisfactory distribution of internal actions among the walls of an inelastic structure.

When two or more walls in the same plane are interconnected by beams, as is the case in coupled shear walls shown in figure 17, it will be necessary to account for more rigid end-zones where beams frame into walls. Such structures should be modelled as shown in figure 7a. Standard programs written for frame analyses^(6,7) may then be used. Alternatively coupled shear walls may be modelled by replacing the discrete coupling beams with a continuous set of elastic connecting laminae⁽²⁾ as shown in figure 7b. The internal actions resulting from such an analysis can be readily converted into discrete moments, shear or axial forces that develop in each floor level. The results of such an analysis are shown in figure 8. The continuous curves for beam shear, moment and axial load on the walls result from the mathematical modelling used in figure 7b. The stepped lines in figure 8 show the conversion of these quantities into usable design actions.

The analysis of wall sections

Because of the variability of wall section shapes, design aids, such as axial load-moment interaction charts for rectangular column sections, cannot often be used. The designer will have to resort to the working out of the required flexural reinforcement from first principles. Programs can readily be developed for minicomputers to carry out the section analysis. The manual section design usually consists of a number of successive approximation analyses of trial sections.

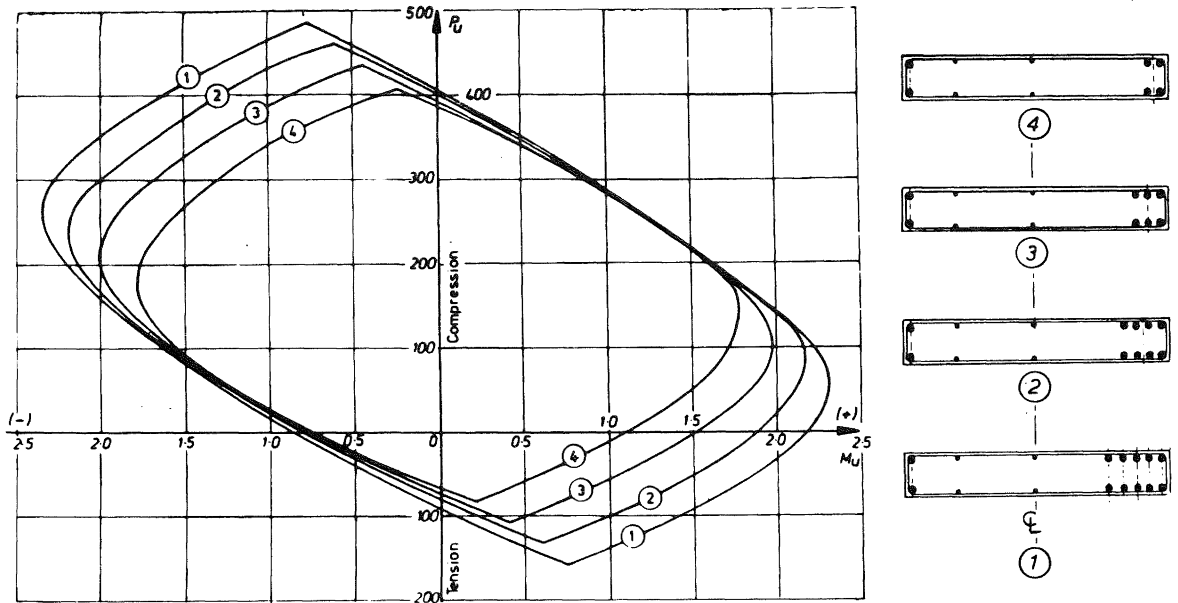

Fig. 9 - Axial Load-Moment Interaction Curves for an Unsymmetrical Shear Wall Section.

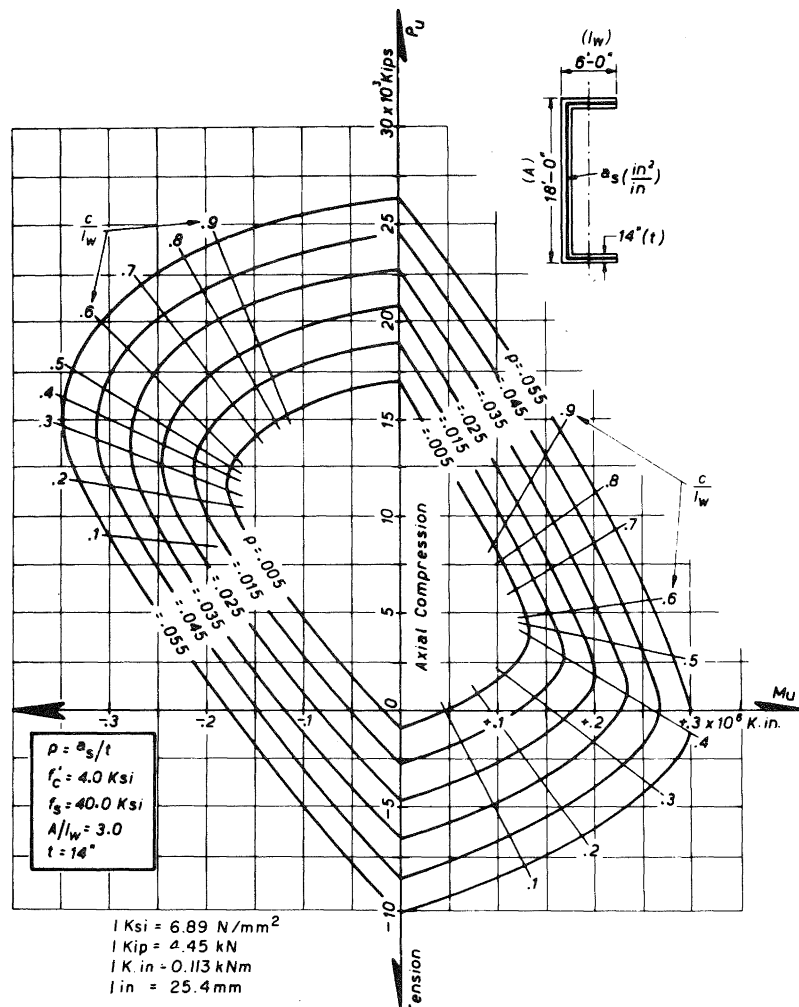

Fig. 10 - Axial Load-Moment Interaction Curves for a Channel Shaped Wall Section (2)

With a little experience convergence can be fast.

One of the difficulties that arises in the section analysis for flexural strength, with or without axial load, is the multi-layered arrangement of reinforcement. A very simple example of such a wall section is shown in figure 9. The four sections are intended to resist the design actions at four different levels of the structure. When the bending moment (assumed to be positive) causes tension at the more heavily reinforced right hand edge of the section, net axial tension is expected on the wall. On the other hand, when flexural tension is induced at the left hand edge of the section by (negative) moments, axial compression is induced in that wall. It is a typical loading situation in one wall of a coupled shear wall structure, such as shown in figure 7.

The moments are expressed with an eccentricity of the axial load, measured from the axis of the section, which, as stated earlier, is taken through the centroid of the gross concrete area rather than through that of the composite section. It is expedient to use the same reference axis also for the analysis of the cross section. It is evident that the plastic centroids in tension or compression do not coincide with the axis of the wall section. Consequently the maximum tension or compression strength of the section, involving uniform strain across the entire wall section, will result in axial forces that act eccentrically with respect to the axis of the wall. These points are shown in figure 9 by the peak values at the top and bottom meeting points of the four sets of curves. This representation enables the direct use of moments and forces, which have been derived from the analysis of the structural system, because in both analyses the same reference axis has been used.

Similar moment-axial load interaction relationships can be constructed for different shapes of wall cross section. An example for a channel shaped section is shown in figure 10. It is convenient to record in the analysis the neutral axis positions for various combinations of moments and axial forces, because these give direct indication of the curvature ductilities involved in developing the appropriate strengths, an aspect examined in "Limitations on Curvature Ductility".

Analyses for Equivalent Lateral Static Loads

The selection of load

The selection of the lateral static load, to determine the appropriate design actions which in turn lead to the desired strength, is in accordance with the earthquake provisions of the loadings code⁽¹⁾. Suitable structural type factors, S , which affect the total design base shear, have been suggested in "Types of Ductile Structural Walls" and elsewhere⁽³⁾.

To determine the magnitude of the basic seismic coefficient the period of the structure is required. This in turn involves the estimation of the structural stiffness at a state when, due to high intensity elastic dynamic excitation, the reinforced concrete components have extensively cracked. A suggested procedure for estimating stiffnesses for this purpose is outlined in "Modelling of member properties".

With this information the intensity of the lateral design loading and its distribution over the height can be determined because all other parameters (such as importance and risk factors) are specified in the loadings code⁽¹⁾. Using the appropriate model, described in the previous section, the analysis to determine all internal design actions may then be carried out.

Redistribution of actions in the inelastic structure

Because the structure is expected to be fully plastic when it develops its required strength, a departure from the elastic distribution of actions in walls linked together is acceptable as long as the total strength of the system is not reduced. For example the elastic analysis for the prescribed load may have resulted in bending moment patterns in three identically distorted shear walls, as shown in figure 11 by the full line curves. It is seen that these are proportional to the stiffnesses that were defined in "Modelling of member properties". It may be desirable to allocate more load to wall 3 because, for example in the presence of more axial compression, it could resist more moment with less flexural reinforcement (see figure 9). As the dashed curves show the design moments for wall 1 and wall 2 have been reduced and those of wall 3 have been increased by the same amount, so that no change in the total moment of resistance occurs.

In order to ensure that there will be no significant difference in the ductility demands when all three walls are required to develop plastic hinges, it is recommended that moment redistribution between walls should not change the maximum value of the moment in any wall by more than 30%. This is seen to be satisfied in the example shown in figure 11. When such redistribution is used in the design of walls, the floor diaphragms should also be designed to be capable of transferring the corresponding forces to each wall.

Similar consideration suggests that, if necessary, the maximum shear force indicated by the elastic analysis in coupling beams of shear walls could be reduced by up to 20% provided that corresponding increases in the shear capacities of beams at other floors are made. With reference to figure 8, this would mean a reduction of the shear forces at and in the vicinity of the 3rd storey with appropriate increases

in the lower and particularly upper storeys, so that the total area within curve "q" does not decrease.

These design quantities may then be used to proportion the wall sections so as to provide the required dependable strength in accordance with the Concrete Design Code⁽⁸⁾.

Dynamic Analyses

For most buildings in which reasonable uniformity in layout and stiffness prevails over the height of the structure, the derivation of design quantities from an elastic analysis for the code⁽¹⁾ specified lateral static loading is likely to assure as satisfactory a seismic performance as a more sophisticated dynamic analysis. However, when abrupt changes, such as setbacks or other discontinuities, occur, the dynamic response may expose features which may not be adequately provided for if the static analysis is used. For such situations the spectral modal dynamic analysis is recommended^(1,19). The results need to be scaled and if necessary the static load analysis may be suitably adjusted to provide the desired design quantities.

For unusual buildings or for special structures a time history dynamic analyses may be necessary. With the development of analysis programs^(6,9), in which the cyclic response of plastic hinges can be modelled with a high degree of sophistication, it is now possible to predict the response of a building to a selected ground excitation. In this, moments, shear and axial forces as well as inelastic deformations, deflections, storey drifts etc. are evaluated at every time step during the specified earthquake record. Maxima encountered during the entire duration of the excitations are also recorded. It is an analysis and not a design tool, and for this reason it may be used to check the performance of the structure as designed. In the definition of properties the probable strengths of the critical regions, discussed in "Probable Strength", should be used. The analysis may warrant certain changes to be made.

In the selection of earthquake records the designers should consider a representative excitation for the locality, which might test the design for its suitability in damage control. Such an analysis will reveal whether adequate stiffness has been provided. A viscous damping of 5% critical is suggested for such analyses.

Another study may be made for an earthquake record representing the largest credible excitation that would be expected in the locality during the probable life of the building. Thereby the inelastic deformations, such as plastic hinge rotations, and maximum actions, such as shear forces across inelastic regions of shear walls, can be predicted and hence compared with values that were envisaged in the design. For such a study a viscous damping of 8-10% of critical may

be used.

Torsion

As in all structures in seismic areas, symmetry in structural layout should be aimed at. This will reduce torsional effect due to the noncoincidence of the centre of rigidity, CR, (centre of stiffness) and the centre of gravity, CG, (centre of mass). Typical eccentricities with respect to the two principal actions of design loading, e_x and e_y , are shown for a set of shear walls of an apartment building in figure 12. Deliberate eccentricities should be avoided, if possible, because uneven onset of plasticification during large excitations may aggravate eccentricity and this in turn may lead to excessive ductility demand in lateral load resisting elements situation far away from the centre of rotation.

An example of the unintended inelastic response of two ductile shear walls is illustrated in figure 13a. Because the centre of the mass, CG, is approximately at the centre of the plan, approximately one half of the induced earthquake load, E, will have to be resisted by each of the end walls at A and B. It may be difficult to prevent Wall A from having a lateral load carrying capacity considerably in excess of that on Wall B. Hence energy dissipation due to inelastic deformation may well be restricted to Wall B only which, as a result of this, could be subjected to a displacement, Δ , much larger than expected. Irrespective of the relative stiffness or strength of the two shear walls, structures in which only two principal planes of lateral resistance exist parallel to either major axes, are likely to be torsionally unstable during large inelastic seismic excitations.

The structural layout shown in figure 13b is symmetrical with respect to the earthquake loading E. It is seen that any eccentricity introduced during the inelastic response of the two end walls will result in torsion which is readily restricted by three walls acting in the perpendicular direction. These walls are likely to remain elastic and hence they will ensure a uniform inelastic translation of each floor, thereby reducing the ductility demand on each of the end walls at A and B.

The example structure shown in figure 13b also shows that, in spite of considerable eccentricity, it is likely to be much more tolerant with respect to horizontal earthquake loading, H, in the other direction. The very significant torsional resistance of the two end walls, at A and B, can ensure that the other three walls will dissipate seismic energy because of approximately equal inelastic wall displacements in the direction of the excitation H. Figure 13b thus shows a desirable, torsionally stable structural layout in which the full utilization of walls in one direction of seismic actions

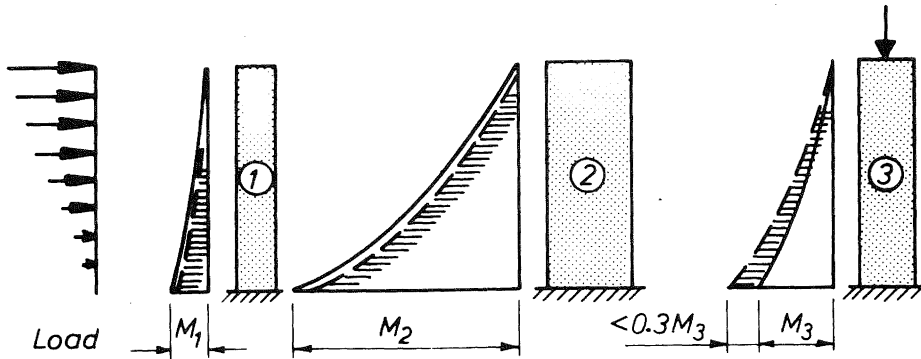

Fig. 11 - Load Redistribution between Three Inelastic Shear Walls.

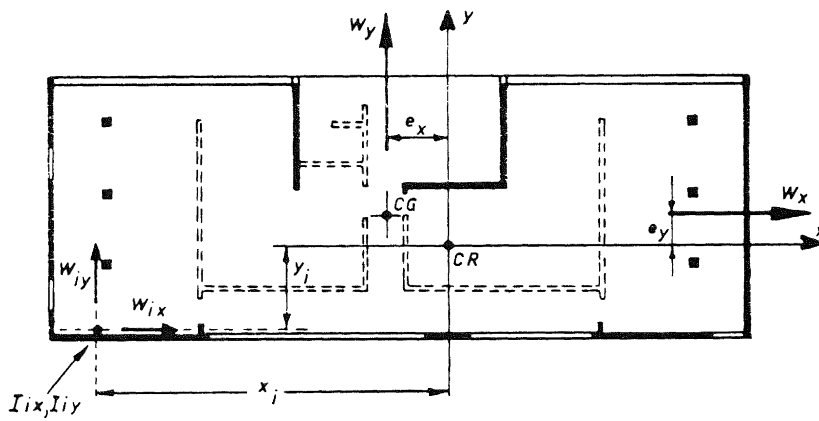

Fig. 12 - Shear Wall Layout for an Apartment Building (2)

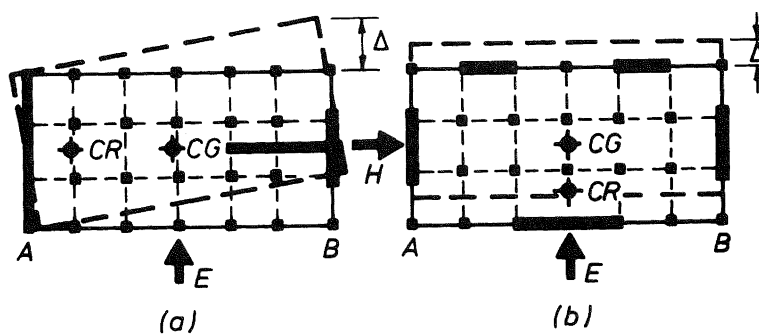

Fig. 13 - The layout of Shear Walls affects the Torsional Stability of the Lateral Load Resisting System.

is enhanced by (elastic) walls acting in the perpendicular direction by preventing inelastic storey twist.

Small single shear cores are particularly vulnerable to torsional instability.

CAPACITY DESIGN PROCEDURES:

The Definition of Strength

Before a hierarchy in the establishment of desirable energy dissipating mechanisms can be established, it is necessary to define the various strengths that might have to be quantified in the design. These have been studied in recent publications^(2,8) and for this reason only a brief summary of the definitions and their relative values are given here.

Ideal strength

The ideal or nominal strength of a section is obtained from established theory predicting failure behaviour of the section, based on assumed section geometry, the actual reinforcement provided and specified material strengths, such as f'_c and f_y .

Dependable strength

To allow for the variations in strength properties and the nature and consequence of the failure, only a fraction of the ideal strength is relied upon to meet the load demand specified by the loadings code⁽¹⁾. Therefore strength reduction factors, ϕ , are introduced⁽⁸⁾ to arrive at the dependable or reliable strength thus:

$$\text{Dependable Strength} = \phi \text{ Ideal Strength}$$

Probable strength

Routine testing of materials or components indicates the probable strength attainable by prototype components in the structure. The designer will seldom require this information. However, when the likely dynamic response of a shear wall structure during a selected ground excitation is to be studied analytically, as discussed in "Dynamic Analyses", it is more appropriate to consider the probable properties of materials at critical member sections.

Overstrength

The overstrength takes into account all the possible factors that may cause a strength increase above the ideal strength. These include steel strength higher than the specified yield strength and the additional strength due to strain hardening at large deformations, concrete strength higher than specified, section sizes larger than assumed in the initial design, increased axial compression strength in flexural members due to lateral confinement of the concrete, and participation of additional reinforcement such as that placed nearby for construction purposes.

Relationship between strengths

When using Grade 275 flexural reinforcement made in New Zealand the following relationships, based on the actual reinforcement provided, may be used to determine the flexural strengths of members -

- (i) Dependable Strength = 0.90 Ideal Strength
- (ii) Probable Strength = 1.15 Ideal Strength
- (iii) Overstrength = 1.25 Ideal Strength
- (iv) Overstrength = 1.39 Dependable Strength
- (v) Probable Strength = 0.90 Overstrength
- (vi) Probable Strength = 1.28 Dependable Strength

It is preferable, however, to determine these values from measured properties of the steel to be used.

It is recommended that wherever design actions, such as shear forces across shear walls, are derived from the flexural overstrength of the wall, the ideal strength be considered to be sufficient to resist it. Whereas in strength design the actions derived from factored loads, such as moment, M_u , or shear, V_u , need to be equal or smaller than the corresponding dependable strength provided, such as ϕM_i or ϕV_i , where M_i and V_i refer to ideal strengths of a section, in capacity design the criteria should be met:

$$M^O \leq M_i \quad \text{or} \quad V^O \leq V_i \quad (\text{B-16})$$

where M^O and V^O are the design actions at a particular section derived from capacity design procedures.

Cantilever Walls

The determination of the flexural and shear load on cantilever walls, taking into account moment redistribution as outlined in "Redistribution of actions in the inelastic structure", is a simple procedure.

The consideration of flexure and overstrength

When the appropriately factored gravity forces are also considered the required flexural reinforcement can be readily determined from the principles reviewed in 'The analysis of wall sections'. In this the designer should attempt to provide the minimum flexural reinforcement to just satisfy the dependable moment demand at the wall base. Apart from economy it should be the designer's aim to keep the overstrength of the wall to the minimum, otherwise demands for shear resistance and on the foundations might be unnecessarily compounded. In very lightly loaded walls, minimum requirement for wall reinforcement may override this criterion. The flexural overstrength is expressed by the "overstrength factor", ϕ_o , which is defined as follows:

$$\phi_o = \frac{\text{overstrength moment of resistance}}{\text{moment resulting from code loading}} = \frac{M^o}{M_{\text{code}}} \quad (\text{B-17})$$

where both moments refer to the base section of the wall.

Even though in most walls Grade 380 reinforcement will be used, the flexural overstrength at the base may be assumed to be only 1.25 times the ideal flexural strength of that section. The reason for this is that cantilever walls will seldom be required to develop plastic hinge rotations involving excessive strain hardening of the tensile reinforcement. However, if wall configuration, slenderness or load demand indicate that tensile strains in excess of 10 times yield strain may be involved with Grade 380 reinforcement, it should be assumed that $\phi_o = 1.6$. It should also be appreciated that in compression dominated wall sections the flexural resistance will be significantly larger if the concrete strength at the time of the earthquake is much in excess of the specified value f'_c .

Moment design envelopes

Once the flexural overstrength of a cantilever wall is determined at its base, it is necessary to define the reduction of moment demand at upper floors.

This used to be done by utilising the bending moment diagram. It is to be recognized, however, that the moment envelope that would be obtained from a dynamic analysis is quite different from the bending moment diagram drawn for the specified lateral static load. This has been identified from modal spectral analyses⁽¹²⁾ as well as from time history dynamic studies⁽¹³⁾. Typical bending moment envelopes for 20 storey cantilever shear walls with different base yield moment capacities, subjected to a particular ground excitation, are shown in figure 14. It is seen that there is an approximate linear variation of moment demand during dynamic excitations.

If the flexural reinforcement in a cantilever wall were to be curtailed according to the bending moment diagram, then flexural yielding (plastic hinges) could occur anywhere along the height of the building. This would be undesirable because potential plastic hinges do require special detailing, and hence more transverse reinforcement. Moreover, flexural yielding reduces the potential shear resisting mechanisms, and this again would require additional (horizontal) shear reinforcement at all levels where hinging might occur. This is discussed in "Control of Diagonal tension and compression".

For the reasons enumerated above it is recommended that the flexural reinforcement in a cantilever wall be curtailed so as to give a linear variation of moment of resistance. The recommendation is illustrated in figure 15. The linear envelope, shown by the dashed line, should be displaced by a distance equal to the horizontal length of the wall, l_w . This

allows for the fact that due to shear the internal flexural tension in a beam section at a section is larger than the bending moment at that section would indicate^(2,8). Accordingly the design envelope, indicating the minimum ideal moment of resistance to be provided, is obtained. Vertical flexural bars in the cantilever wall, to be curtailed must extend beyond the section indicated by the design envelope of figure 15, by at least the development length for such bar⁽⁸⁾.

Flexural ductility of cantilever walls

To ensure that a cantilever wall can sustain a substantial portion of the intended lateral load at a given displacement ductility ratio, μ_Δ , it is necessary that it can develop in its plastic hinge at the base a certain curvature ductility ratio, μ_ϕ . These ductility ratios are traditionally defined as follows:

Displacement ductility ratio:

$$\mu_\Delta = \frac{\Delta_u}{\Delta_y} \quad (\text{B-18})$$

Curvature ductility ratio:

$$\mu_\phi = \frac{\phi_u}{\phi_y} \quad (\text{B-19})$$

where Δ_u and Δ_y are the deflections at the top of the cantilever at the ultimate state and at the onset of yielding and ϕ_u and ϕ_y are the corresponding curvatures i.e. rotations of the section, at the base of the cantilever.

The relationship between the curvature ductility of the base section and the displacement ductility of the wall will depend on the length of the plastic hinge at the base⁽²⁾ and the wall height to horizontal length ratio, h_w/l_w . The variation of curvature ductility demand with h_w/l_w for various displacement demands is shown in figure 16. The dark bands represent the limits for the length of the plastic hinge, as obtained from two different proposed equations⁽¹⁴⁾. It is seen that for slender cantilever walls which are expected to be subjected to a displacement ductility demand of four, very considerable curvature ductility will need to be developed at the base. This will need to be taken into consideration when the detailing of the potential plastic hinge zone is being undertaken. (See "Satisfying Ductility Demands").

Shear strength of cantilever walls

It was emphasized in the previous sections that if a shear failure is to be avoided, the shear strength of a wall must be in excess of the maximum likely shear demand. Therefore the shear strength must be at least equal to the shear associated with the flexural overstrength of the wall i.e. $V_{\min} \geq \phi_o V_{\text{code}}$.

It has been demonstrated that during the inelastic dynamic response of a shear wall, with a given base hinge moment capacity,

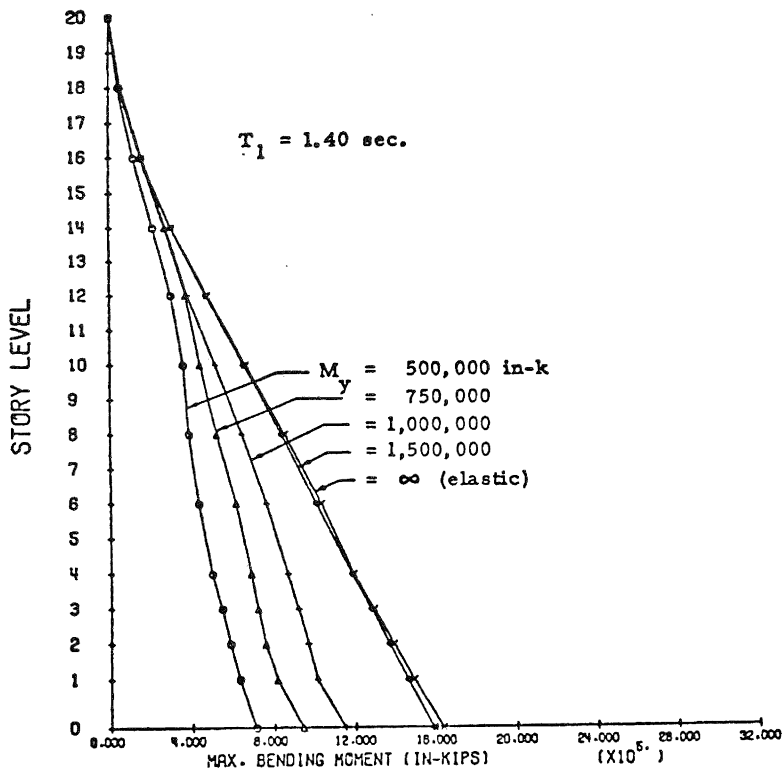

Fig. 14 - Dynamic Bending Moment Envelopes for a 20 Storey Shear Wall with different Base Yield Moment Capacities (13).

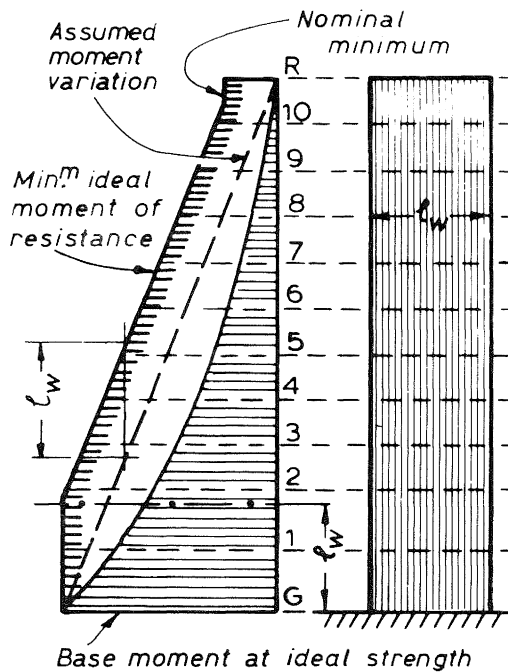

Fig. 15 - Recommended Design Bending Moment Envelope for Cantilever Shear Walls.

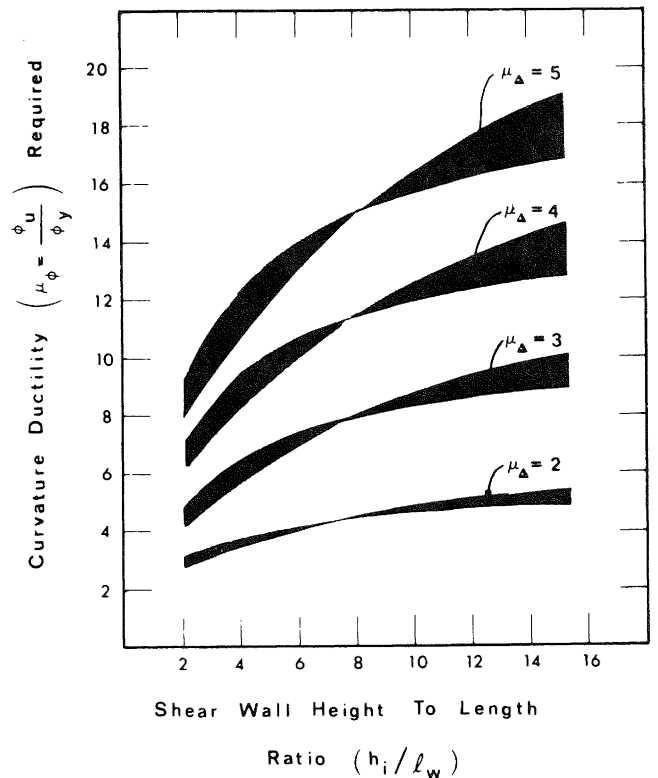

Fig. 16 - The Variation of Curvature Ductility at the base of Cantilever Shear Walls with the Aspect Ratio of the Walls and the Imposed Displacement Ductility Demand (14).

considerably larger shear forces can be generated than those predicted by static analysis⁽¹²⁾. For this reason the design shear forces must be magnified further. Therefore cantilever shear walls at all levels should possess an ideal shear capacity, V_i , of not less than

$$V_{wall} = \omega_v \phi_o V_{code} \quad (B-20)$$

where V_{code} is the shear demand derived from code(I) loading, ϕ_o was defined by Eq. (B-17) and the dynamic shear magnification factor is given by Eq. (B-21) for buildings up to 5 storeys high

$$\omega_v = 0.1N + 0.9 \quad (B-21)$$

where N is the number of storeys. For walls taller than 5 storeys the value of ω_v is given in Table B-I⁽¹²⁾. However, the ideal shear strength need not exceed

$$V_{wall} < (4/S) V_{code} \quad (B-22)$$

TABLE B-1

DYNAMIC SHEAR MAGNIFICATION FACTOR ω_v	
Number of Storeys	ω_v
1 to 5	Eq. (B-21)
6 to 9	1.5
10 to 14	1.7
15 and over	1.8

It may be that the flexural capacity provided at the base of the structure is so large that inelastic response of the shear wall will become unlikely. For such situations

Eq. (B-22) sets an upper limit whereby the product $\omega_v \phi_o$ need not be larger than 4/S. For example a single 8 storey cantilever shear wall need not possess an ideal shear strength in excess of $4/1.2 = 3.33$ times the code specified shear load, V_{code} .

The provisions to meet the design shear load V_{wall} from Eq. (B-20) are given in "Control of shear failure".

Coupled Shear Walls

In the following sections a recommended step by step capacity design procedure for coupled shear walls is outlined. When necessary reference should be made to figure 7 or figure 17.

Geometric review

Before the static analysis procedure commences the geometry of the structure should be reviewed to ensure that in the critical zones compact sections, suitable for energy dissipation, will result. Section configurations should satisfy criteria outlined in "Stability".

Lateral static load

The appropriate lateral static load, in accordance with the loadings code⁽¹⁾ is to be determined. To do this it might be necessary to estimate the probable value, S_p , of the structural type factor S, recommended in "Types of Ductile Structural Walls"(b).

Elastic analysis

With the evaluation of the lateral static load the complete analysis for the resulting internal structural actions, such as moments, forces etc. can be carried out. In this the modelling assumption of "Modelling Assumptions" should be observed. Typical results are shown in figure 8.

Confirmation of the structural type factor

Having obtained the moments and axial forces at the base of the structure the moment parameter

$$A = \frac{T\ell}{M_o} \quad (B-1)$$

as discussed in "Types of Ductile Structural Walls"(b), can be determined. The significance of the parameter may also be seen in figure 18. With the use Eq. (B-3) the exact required value of the structural type factor, S can be found. If this differs from that assumed earlier i.e. S_p , all quantities of the elastic analysis are simply adjusted by the multiplier S/S_p .

Checking of foundation loads

To avoid unnecessary design computations, at this stage it should be checked whether the foundation structure for the coupled shear walls would be capable of transmitting at least 1.5 times the overturning moment, M_o , received from the superstructure (see figure 17), to the foundation material (soil). It is to be remembered that in a carefully designed superstructure, in which no excess strength of any kind has been allowed to develop, 1.4 times the overturning moment resulting from code loading M_o will be mobilized during large inelastic displacements. (See "Relationship between strengths"). Hence the foundation system must have a potential strength in excess of $1.4 M_o$, otherwise the intended energy dissipation in the superstructure may not develop.⁽⁵⁾

Design of coupling beams

Taking flexure and shear into account the coupling beams at each floor can be designed. Normally diagonal bars in cages⁽²⁾ should be used, preferably with Grade 275 reinforcement. A strength reduction factor of $\phi = 0.9$ is appropriate. Particular attention should be given to the anchorage of caged groups of bars and to ties which should prevent inelastic buckling of individual diagonal bars. (See "Detailing of Coupling Beams"). The beam reinforcement should match as closely as possible the load demand. Excessive coupling beam strength may lead to subsequent difficulties in the design of walls and foundations.

Determination of actions on the walls

In order to find the necessary vertical reinforcement in each of the coupled walls (figure 17) at the critical

base section, the following loading cases should be considered:

i) $P_e = P_{eq} - 0.9P_D$ axial tension (or small compression) and M_1

ii) $P_e = P_{eq} + P_D + P_{L,R}$ axial compression and M_2

where P_e = axial design load including earthquake effects

P_{eq} axial tension or compression induced in the wall by the lateral static loading

P_D = axial compression due to dead load

$P_{L,R}$ = axial compression due to reduced live load L_R

M_1 = moment at the base developed concurrently with earthquake induced axial tension load (figure 17c)

M_2 = moment at the base developed concurrently with earthquake induced axial compression load (figure 17c)

iii) If case (i) above is found to result in large demand for tension reinforcement or for other reasons, a redistribution of the design moments from the tension wall to the compression wall may be carried out in accordance with 'Redistribution of actions in the inelastic structure', within the following limits:

(a) $M'_1 > 0.7 M_1$

(b) $M'_2 = M_2 + M_1 - M'_1 < 1.3 M_2$

where M'_1 and M'_2 are the design moments for the tension and compression walls respectively, after the moment redistribution has been carried out.

In the above three steps, which would complete the strength design of the structure, a capacity reduction factor of $\phi = 0.9$ may be used for all cases. The justification for this is considered to result from a subsequent requirement, according to which compression dominated wall sections specifically need to be confined to ensure sufficient curvature ductility.

Using these quantities the vertical flexural reinforcement for each wall, with Grade 275 or Grade 380 steel, can now be determined in accordance with "The analysis of wall sections".

Overcapacity of coupling beams

In order to ensure that the shear strength of the coupled shear wall structure will not be exceeded and that the maximum load demand on the foundation is properly assessed, i.e. to fulfill the intent of "Hierarchy in Energy Dissipation", the overstrength of the potential plastic regions must be estimated. Accordingly

the shear overcapacity, Q_i^0 , of each coupling beam, as detailed, based on a yield strength of the diagonal reinforcement of $1.25 f_y \geq 345$ MPa is determined. Where slabs, framing into coupling beams, contain reinforcement parallel to the coupling beams which is significant when compared with the reinforcement provided within the beam only, the possible contribution of some of this the reinforcement to the shear capacity of coupling beams should also be considered in computing overstrength.

Earthquake induced axial loads

The maximum feasible axial load induced in one of the coupled walls would be obtained from the summation of all the coupling beam shear forces at overcapacity, Q_i^0 , applied to the wall above the section that is considered. For structures with several storeys this may be an unnecessarily conservative estimate, and accordingly it is recommended that the wall axial load at overstrength be estimated with

$$P_{eq}^0 = (1 - \frac{n}{80}) \sum_i Q_i^0 \quad (B-23)$$

where n = number of floors above level i. The value of n in Eq. (B-23) should not be taken larger than 20.

The flexural overcapacity of the entire structure

In order to estimate the maximum likely overturning moment that could be developed in the fully plastic mechanism of the coupled shear wall structure, it is necessary to assume gravity loads that are realistic and consistent with such a seismic event. Accordingly, for this purpose only, the total overstrength axial loads to be sustained by the walls should be estimated as follows:

i) For tension of minimum compression

$$P_1^0 = P_{eq}^0 - P_D$$

ii) For compression

$$P_2^0 = P_{eq}^0 + P_D$$

It is now possible to estimate the flexural overstrength capacity of each wall section, as detailed, that may be developed concurrently with the above axial forces. The moments of resistance, which may be based on material strengths defined by $1.25f_y$ and $1.25f'_c$, so derived for the tension and compression walls respectively, are M_1^0 and M_2^0 . In similarity to Eq. (B-17) the overstrength factor for the entire coupled shear wall structure may be obtained from

$$\phi_0 = \frac{M_1^0 + M_2^0 + P_{eq}^0 \ell}{M_0} \quad (B-24)$$

In accordance with the assumed strength properties of "Relationship between strengths" the value of ϕ_0 so obtained should not be less than 1.39. If it is, the design should be checked for the error.

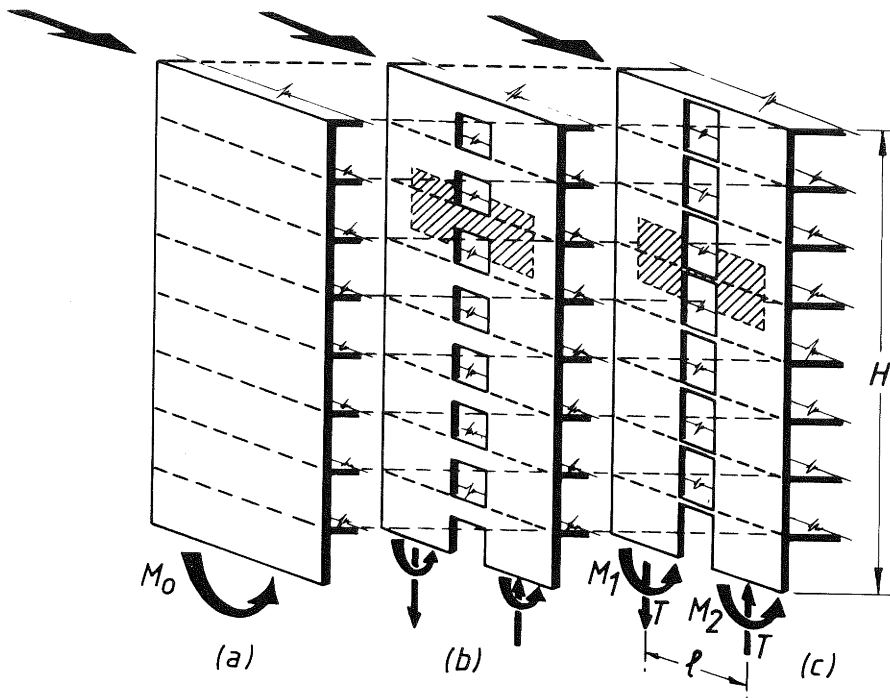

Fig. 17 - A Comparison of Ductile Walls (a) A Cantilever Wall (b) Walls Coupled by Strong Coupled Beams (c) Walls Coupled by Slabs Only.

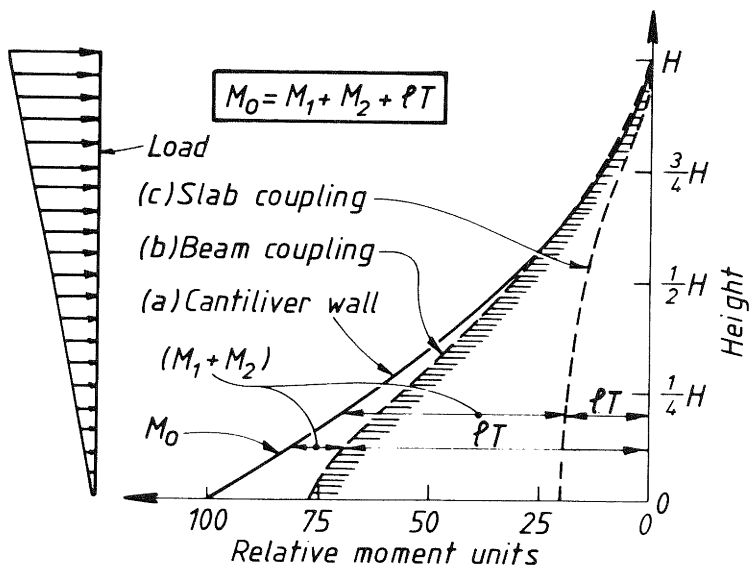

Fig. 18 - Contribution of Internal Coupling to the Resistance of Overturning Moments in Coupled Shear Walls.

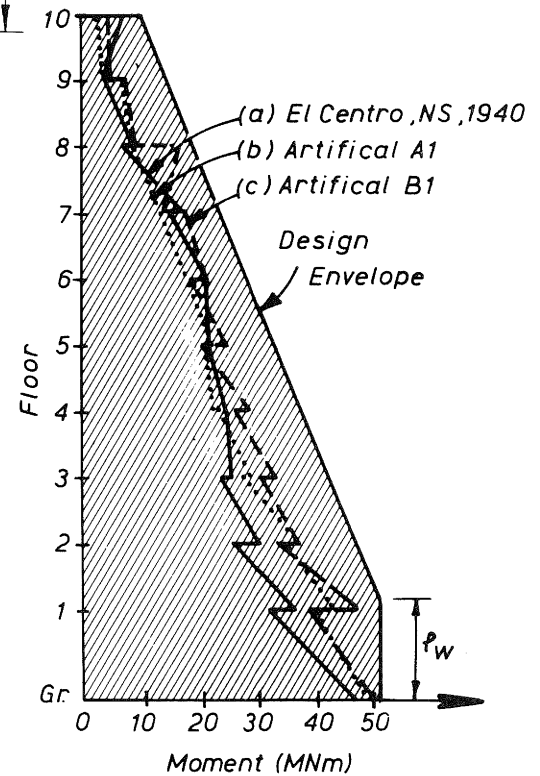

Fig. 19 - Bending Moment Envelopes for Coupled Shear Walls (a) Envelope Used in Design (b) Envelopes Observed in a Theoretical Study (15).

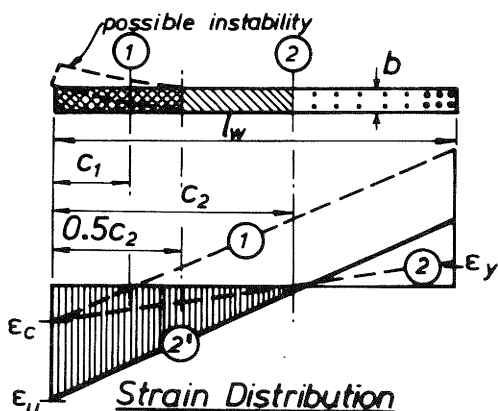

Fig. 20 - Strain Patterns for a Rectangular Wall Section Subjected to Flexure and Axial Load.

Wall shear forces

In similarity to the approach employed in the section "Shear strength of cantilever walls" for cantilever shear walls, the maximum shear force for one wall of a coupled shear wall structure may be obtained from

$$V_{i,wall} = \omega_v \phi_o \left[\frac{M_i^o}{M_1^o + M_2^o} \right] V_{code} ; i = 1, 2 \quad (B-25)$$

where ω_v = dynamic shear magnification factor in accordance with Eq. (B-20)

V_{code} = shear force on the entire shear wall structure at any level, derived by the initial elastic analysis for code loading⁽¹⁾ with the appropriate S factor.

$\omega_v \phi_o \leq 4/S$ in accordance with Eq. (B-22)

The bracketed term in Eq. (B-25) makes an approximate allowance for the distribution of shear forces between the two walls, which, at the development of overstrength, is likely to be different from that established with the initial elastic analysis. It also takes into account the approximate redistribution of shear forces that may have resulted from the deliberate redistribution of design moments from the tension to the compression wall.

The required horizontal shear reinforcement may be determined now. In assessing the contribution of the concrete shear resisting mechanism, the effects of the axial forces P_1^o and P_2^o , as appropriate should be taken into account.

Confinement of wall sections

From the load combinations considered above the positions of the neutral axes relative to the compressed edges of the wall sections are readily obtained. From the regions of the wall section over which, in accordance with the section "Confinement of Wall Regions" anti-buckling and/or confining transverse reinforcement is required, this reinforcement can now be determined.

Curtailement of vertical flexural reinforcement

For the purpose of establishing the curtailement of the principal vertical wall reinforcement, a linear bending moment envelope along the height of each wall should be assumed, as shown in figure 19a. This is intended to ensure that the likelihood of flexural yielding due to higher mode dynamic responses along the height of the wall is minimized. Details for the justification of such an envelope

were examined in the section "Moment design envelopes". In a study, in which the inelastic dynamic response of a coupled shear wall was computed, the moment envelopes for responses to three different ground excitations, shown in figure 19, were obtained⁽¹⁵⁾.

Foundation design

The actions at the development of the overstrength of the superstructure, P_1^o , P_2^o , M_1^o , M_2^o and wall shear forces V_1 and V_2 , should be used as loading on the foundations. For ductile coupled shear walls, the foundation structure should be capable of absorbing these actions at its ideal strength capacity.

SATISFYING DUCTILITY DEMANDS

Stability

When part of a thin wall section is subjected to large compression strains, the danger of premature failure by instability arises. This is the case when a large neutral axis depth is required in the plastic hinge zone of the wall, as shown in figure 20, and the length of the plastic hinge is large i.e. one storey high or more. The problem is compounded when cyclic inelastic deformations occur. Instability should not be permitted to govern strength of ductile shear walls.

In the absence of information on the "compactness" of reinforced concrete wall sections, existing code rules⁽¹⁶⁾, relevant to short columns, are best considered. For such columns the effective height to width ratio, l_n/b , should not exceed 10⁽¹⁶⁾.

The relevance of such a code requirement to a shear wall may be studied with the aid of figure 20. For a certain load combination the computed neutral axis depth may be c_2 , so that a considerable portion of the wall section will be subject to compression. Near the extreme compression fibre, where, in accordance with accepted assumptions, the concrete strain at ideal flexural capacity is taken as $\epsilon_c = 0.003$, instability may occur unless this strain pattern is restricted vertically to a very short plastic hinge length. Moreover, the strain profile marked (2) in figure 20 shows that very limited curvature ductility would be available at the attainment of the ideal strength of the section. To satisfy the intended displacement ductility demand for the shear wall system, a strain profile shown by line (2') may need to be developed. Such large concrete compression strains, ϵ_u , could only develop if the concrete in this zone is confined, and this will be examined in a later section. The phenomenon is fortunately rare, but it emphasizes the need for considering instability. It occurs more commonly when a wall has a large tension flange, such as shown in figure 22 and figure 35.

In the absence of experimental evidence intuitive judgement was used to recommend that, with the exceptions to be

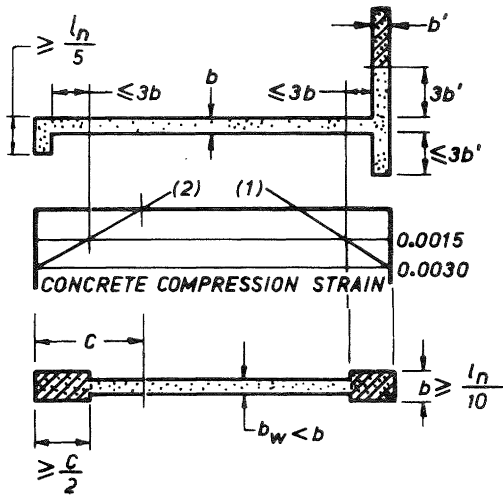

Fig. 21 - Parts of a Wall Section to be Considered for Instability and which Provides Lateral Support.

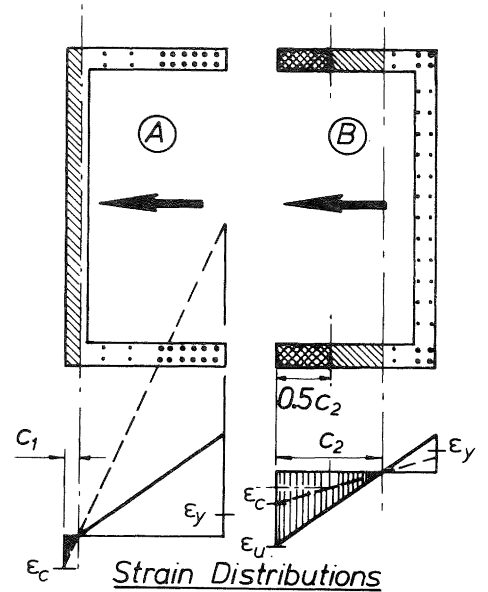

Fig. 22 - Strain Profiles for Channel Shaped Wall Sections.

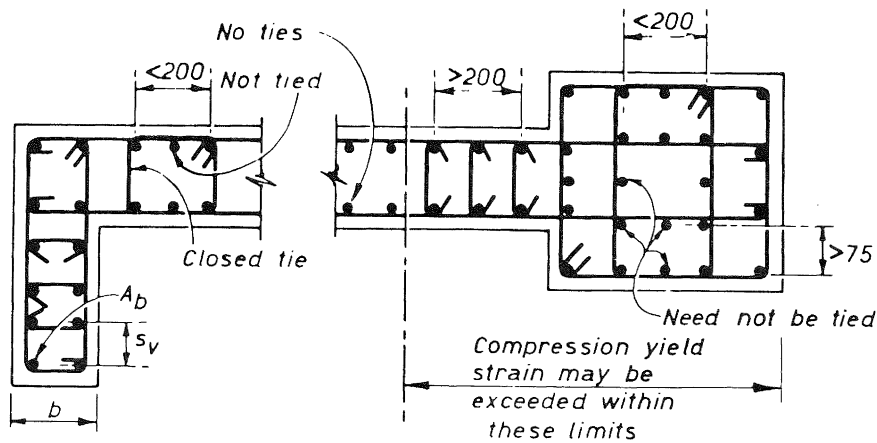

Fig. 23 - Transverse Reinforcement in Potential Yield Zones of Shear Wall Sections.

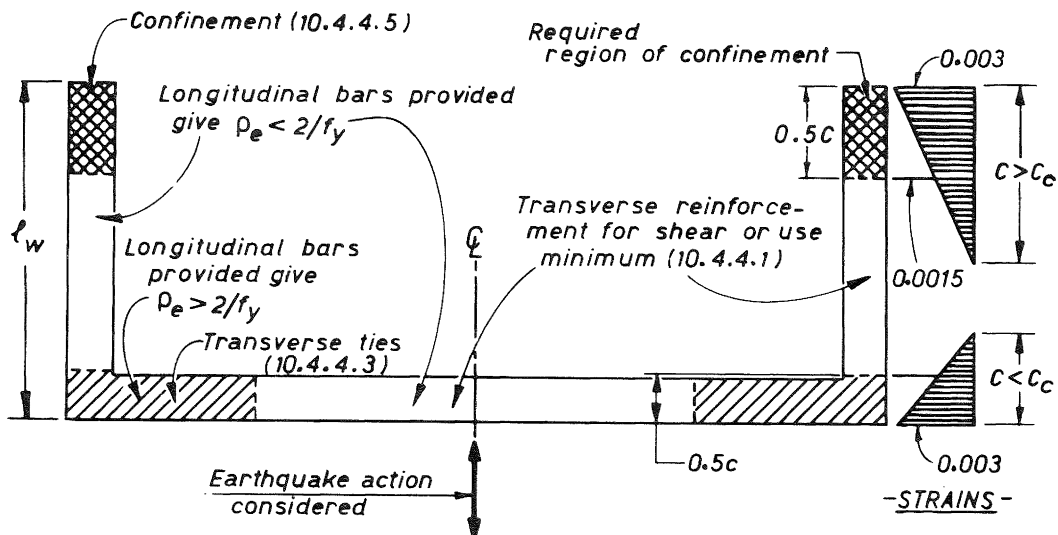

Fig. 24 - Regions of Different Transverse Reinforcement in a Shear Wall Section.

set out subsequently, in the outer half of the conventionally computed compression zone, the wall thickness b should not be less than one tenth of the clear vertical distance between floors or other effective lines of lateral support, ℓ_n . Considering the strain pattern (2) in figure 20, this zone extends over a distance of $0.5c_2$, as shown with cross shading. This is an area over which the concrete compression strain will exceed 0.0015 when the strain in the extreme compression fibre of the section, consistent with the determination of the ideal flexural strength, attains its assumed maximum value of 0.003.

When the computed neutral axis depth is small, as shown by the strain distribution (1) in figure 20, the compressed area may be so small that adjacent parts of the wall will stabilize it. Accordingly, when the fibre of 0.0015 compression strain is within a distance of the lesser of $2b$ or $0.15 \ell_n$ from the compressed edge, the $b > \ell_n/10$ limit should not need to be complied with. In terms of neutral axis depth this criteria is met when $c \leq 4b$ or $c \leq 0.3 \ell_n$, whichever is less. The strain profile (1), which occurs commonly in lightly reinforced walls with small gravity load, clearly satisfies this condition.

It may be assumed that only in buildings 3 storeys or higher would the plastic hinge length at the base, extending toward the first floor, be large enough to warrant an examination of instability criteria.

Certain components of walls, such as shown in figure 21, provide continuous lateral support to adjacent compressed elements. Therefore it is considered that any part of a wall, subjected to computed strains larger than 0.0015, which is within a distance of $3b$ of such a line of support, should be exempted from slenderness limitation. Figure 2 shows a number of locations that are exempt. The shaded part of the flange is considered to be too remote to be effectively restrained by the web portion of the wall and hence it should comply with the $b > \ell_n/10$ slenderness limitation. In the absence of a flange, the width of which is at least $\ell_n/5$, a boundary element may be formed that satisfies the slenderness limit. These latter two cases are also shown in figure 21.

Limitations on Curvature Ductility

By simple limitations of the amount of flexural tension reinforcement⁽⁸⁾ in beam sections, it can be ensured that adequate curvature ductility, to meet the intents of seismic design, will be available. Because of the variety of cross sectional shapes and arrangements of reinforcements that can be used, and the presence of some axial load, the availability of ductility in shear walls cannot be checked by the simple process that is used for rectangular beams or sections.

In the analysis of wall sections for flexure and axial load, the neutral axis depth, c , is always determined. Hence the ratio of c/ℓ_w , an indicator of the curvature ductility required at the development of the ideal strength, (figure 21) can be readily found. Various strain profiles, associated with a maximum assumed concrete compression strain of $\epsilon_c = 0.003$ are shown by dashed lines in figures 20 and 22. It is seen that different neutral axis depths, c_1 and c_2 , for different wall configurations can give very different curvature ductilities.

The curvature ductility demand in the plastic hinge zone of cantilever walls was related to the displacement ductility in 'Flexural ductility of cantilever walls'. Typical relationships were also presented in figure 16. It will be seen that in a relatively slender shear wall with $h_w/\ell_w = 8$, a curvature ductility of approximately 11 is required if the displacement ductility is to be 4. The yield curvature of a section may be approximated by $\phi_y = (\epsilon_y + \epsilon_{ce})/\ell_w \approx 0.0025/\ell_w$ where ϵ_y and ϵ_{ce} are the steel and concrete strains at the extreme edges when the yield strain of the reinforcement is just reached. Hence the desired ultimate curvature will be $\phi_u = 11\phi_y = 0.0275/\ell_w$. Current strength computations are based on the conservative assumption that $\epsilon_c = 0.003$. It is found, however, that a strain of 0.004 can be readily attained in the extreme compression fibre of a section before crushing of the concrete commences⁽²⁾. By assuming that the maximum concrete strain will reach the value of 0.004 it is found that the neutral axis depth at this curvature needs to be $c = 0.004 \ell_w / 0.0275 = 0.145 \ell_w$. As figure 16 shows however, for h_w/ℓ_w ratios less than 8 lesser curvature ductilities will suffice.

The above discussion was based on cantilevers, for which a structural type factor of $S = 1$ is relevant, and for which a displacement ductility demand of 4 might arise when the intended base overstrength, corresponding with $\phi_o = 1.39$, is developed. For walls with larger S factors or larger unintended overstrength (i.e. when $\phi_o > 1.39$), the displacement ductility requirement may be assumed to be proportionally reduced. Consequently the critical neutral axis depth can be conservatively assumed to be

$$c_c = 0.10 \phi_o S \ell_w \tag{B-26}$$

If desired, the designer could carry out a more refined analysis, using Eq. (B-27) which may show that a larger neutral axis depth would provide the desired curvature ductility.

$$c_c = \frac{8.6 \phi_o S \ell_w}{(4 - 0.7S) (17 + h_w/\ell_w)} \tag{B-27}$$

Whenever the computed neutral axis depth for the design loading on the given section exceeds the critical value c_c , given by Eq. (B-26), it will be necessary to assume that increased ductility can be attained only at the expense of increased concrete compression strains.

It is seen on the left hand side of figure 22, showing the channel shaped cross section of a single cantilever wall, that, because of the large available concrete compression area, very large curvature ductility is associated with the development of the flexural strength. A given displacement ductility, however, may require only a strain pattern shown by the heavy line. It is evident that this curvature could only be attained in the other wall section, shown on the right in figure 22, if the concrete compression strains increase considerably. The same relationship can be seen between the strain patterns (1) and (2') shown in figure 20. Excessive compression strains would lead to failure of the section unless the concrete in the core of the compression zone is suitably confined. This aspect of the design is examined in the next section.

Confinement of Wall Regions

From the examination of curvature relationships in the simple terms of c/ℓ_w ratio, it is seen that in cases when the computed neutral axis is larger than the critical value c_c , given by Eq. (B-26) or Eq. (B-27), the compression region of the wall needs to be confined. It does not seem necessary to confine the entire compression zone. It is suggested, however, that the outer half of it be confined. Accordingly the following simple rules are suggested.

Region of confinement

When the neutral axis depth in the potential yield regions of a wall, computed for the most adverse combination of design loadings, exceeds

$$c_c = 0.10 \phi_o S \ell_w \quad (B-26)$$

the outer half of the compression zone, where the compression strain, computed when the ideal flexural strength of the section is being determined, exceeds 0.0015, should be provided with confining reinforcement. This confining transverse reinforcement should extend vertically over the probable plastic hinge length, which for this purpose should be assumed to be equal to the length of the wall ℓ_w , as shown in figure 15 and figure 19.

Confining reinforcement

The principles of concrete confinement (2) to be used are those relevant to column sections, with the exceptions that very rarely will the need arise to confine the entire section of a shear wall. Accordingly it is recommended that rectangular or polygonal hoops and supplementary ties, surrounding the longitudinal bars in the region to be confined, should be used so that

$$A_{sh} = 0.3 s_h h'' \left(\frac{A_g^*}{A_c^*} - 1 \right) \frac{f'_c}{f_{yh}} \left(0.5 + 0.9 \frac{c}{\ell_w} \right) \quad (B-28)$$

$$A_{sh} = 0.12 s_h h'' \frac{f'_c}{f_{yh}} \left(0.5 + 0.9 \frac{c}{\ell_w} \right) \quad (B-29)$$

whichever is greater, where the ratio c/ℓ_w need not be taken more than 0.8.

In the above equations:

- A_{sh} = total effective area of hoops and supplementary cross ties in direction under consideration within spacing s_h , mm^2
- s_h = vertical centre to centre spacing of hoop sets, mm
- A_g^* = gross area of the outer half of wall section which is subjected to compression strains mm^2
- A_c^* = area of concrete core in the outer half of section which is subjected to compression strains, measured to outside of peripheral hoop legs, mm^2
- f'_c = specified compression strength of concrete, MPa
- f_{yh} = specified yield strength of hoop or supplementary cross tie steel, MPa
- h'' = dimension of concrete core of section measured perpendicular to the direction of the hoop bars, mm

These equations are similar to those developed by Park⁽¹⁷⁾ for columns. The area to be confined is thus extending to $0.5c_c$ from the compressed edge as shown by cross hatching in the examples of figures 20 and 22.

For the confinement to be effective the vertical spacing of hoops or supplementary ties, s_h , should not exceed 6 times the diameter of vertical bars in the confined part of the wall section, one third of the thickness of the confined wall or 150 mm, whichever is less.

An application of this procedure is given in Appendix II.

Confinement of longitudinal bars

A secondary purpose of confinement is to prevent the buckling of the principal vertical wall reinforcement where the same may be subjected to yielding in compression. It is therefore recommended that in regions of potential yielding of the longitudinal reinforcement within a wall with two layers of reinforcement, where the longitudinal reinforcement ratio ρ_ℓ , computed from Eq. (B-31), exceeds $2/f_{yt}$, transverse tie reinforcement, satisfying the following requirements, should be provided:

- (a) Ties suitably shaped should be so arranged that each longitudinal bar or bundle of bars, placed close to the wall surface, is restrained against buckling

by a 90° bend or at least a 135° standard hook of a tie. When two or more bars, at not more than 200 mm centres apart, are so restrained, any bars between them should be exempted from this requirement.

- (b) The area of one leg of a tie, A_{te} , in the direction of potential buckling of the longitudinal bar, should be computed from Eq. (B-30) where ΣA_b is the sum of the areas of the longitudinal bars reliant on the tie including the tributary area of any bars exempted from being tied in accordance with (a) above.

$$A_{te} = \frac{\Sigma A_b f_y s_h}{16 f_y h} \quad (B-30)$$

Longitudinal bars centered more than 75 mm from the inner face of stirrup ties need not be considered in determining the value of ΣA_b .

- (c) The spacing of ties along the longitudinal bars should not exceed six times the diameter of the longitudinal bar to be restrained.
- (d) Where applicable, ties may be assumed to contribute to both the shear strength of a wall element and the confinement of the concrete core.
- (e) The vertical reinforcement ratio that determines the need for transverse ties should be computed from

$$\rho_\ell = \frac{\Sigma A_b}{bs_v} \quad (B-31)$$

where the terms of the equation, together with the interpretation of the above requirements are shown in figure 23. The interpretation of Eq. (B-31) with reference to the wall return at the left hand end of figure 23 is as follows : $\rho_\ell = 2A_b/bs_v$.

The requirements of transverse reinforcement in a shear wall section are summarized in figure 24 as follows:

- (a) For the direction of loading the computed neutral axis depth c exceeds the critical value c_c , given by Eq. (26) or Eq. (27), hence confining reinforcement over the outer half of the compression zone, shown by cross hatching, should be provided in accordance with "Confining reinforcement".
- (b) In the web portion of the channel shaped wall, within the outer half of the computed neutral axis depth, vertical bars need be confined (using antibuckling ties) in accordance with "Confinement of longitudinal bars" only if $\rho_\ell > 2/f_y$. The affected areas are shaded.
- (c) In all other areas, which are unshaded

the transverse (horizontal) reinforcement need only satisfy the requirements for shear and its ratio to the concrete area should not be less than 0.0025.

Longitudinal Wall Reinforcement

For practical reasons the ratio of longitudinal i.e. vertical reinforcement, ρ_ℓ , (Eq. (B-31)) over any part of wall should not be less than $0.7/f_y$, nor more than $17/f_y$.

In walls which are thicker than 200 mm or when the design shear stress exceeds $0.3 \sqrt{f'_c}$ MPa, at least two layers of reinforcement should be used, one near each side of the wall.

The diameter of bars used in any part of a wall should not exceed one tenth of the thickness of the wall. The spacing between longitudinal bars should not exceed twice the thickness of the wall nor 400 mm.

In regions where the wall section is required to be confined the spacing of vertical bars should not exceed 200 mm.

Control of Shear Failure

Shear forces and shear stresses

The derivation of the design shear forces, using the principles of capacity design, have been outlined previously for cantilever walls ("Shear strength of cantilever walls") and in "Wall shear forces" for coupled shear wall structures. Shear strength provided in accordance with these shear forces is expected to ensure ductile flexural response of walls with an acceptable amount of reduction in energy dissipation during hysteretic response. For convenience and in keeping with traditional practice these forces may be converted into stresses thus

$$v_i = \frac{V_{wall}}{b_w d} \quad (B-32)$$

where the effective depth need not be taken less than $0.8 \ell_w$. Eq. (B-32) should be considered as an index rather than an attempt to quantify a stress level at any particular part of the wall section. From observed behaviour of walls, using this expression, certain limits have been set to ensure satisfactory performance.

Shear may lead to different types of failure, such as diagonal tension, diagonal compression and sliding, each of which are examined subsequently. In general the principles relevant to the design of ordinary reinforced concrete beams⁽²⁾ are also applicable to structural walls.

Control of diagonal tension and compression

Two areas within a wall must be distinguished for which the design procedures

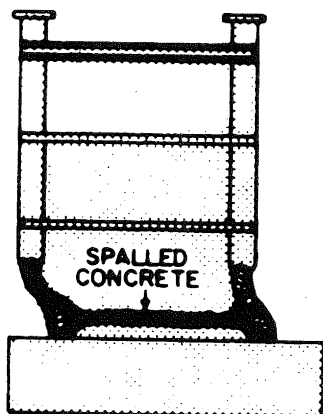

Fig. 25 - Sliding Shear Failure Initiated by Web Crushing.

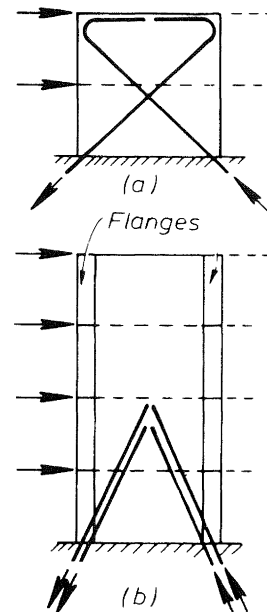

Fig. 26 - Suggestions for the Arrangement of Diagonal Reinforcement to Control Sliding Displacement at the Base.

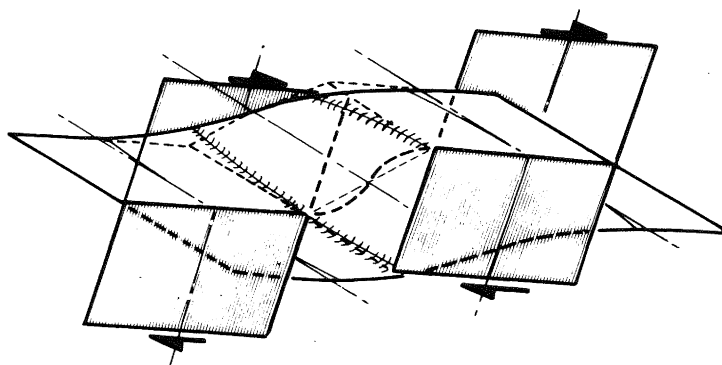

Fig. 27 - The Inelastic Deformations of a Slab Interconnecting two Laterally Loaded Shear Walls.

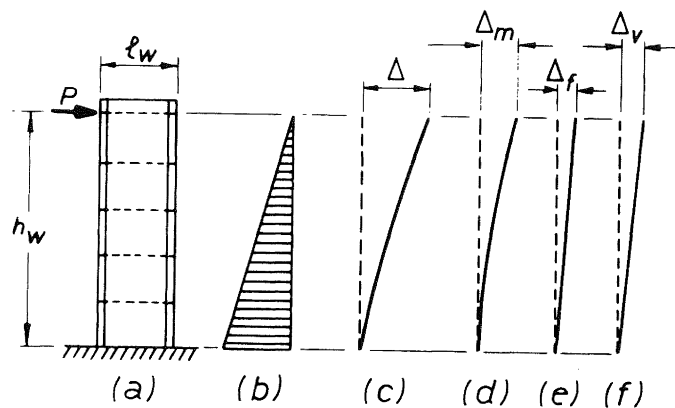

Fig. 28 - A Cantilever Wall and its Distortions.

are different. These are the potential plastic hinge zone and the remainder of the wall, which is expected to remain free of significant flexural yielding during any kind of dynamic excitation. In the design to control diagonal tension, one part of the shear strength is assumed to be provided by the shear reinforcement (v_s) and the other by mechanisms collectively designated as the contribution of the concrete (v_c). Accordingly

$$v_i = v_c + v_s \quad (B-33)$$

In this the contribution of the "concrete" to shear resistance, v_c , is assumed to be zero in the potential plastic hinge zone, unless the minimum design axial load, N_u , produces an average compression stress of $0.1 f'_c$ or more over the gross concrete area, A_g , including flanges, in which case

$$v_c = \frac{2}{3} \sqrt{\left(\frac{N_u}{A_g} - \frac{f'_c}{10}\right)} \quad (B-34)$$

The value of v_c outside the potential plastic hinge zone may be taken as that specified for beams⁽⁸⁾ subjected to gravity (non-seismic) loading only. This will normally result in significant reduction in the web reinforcement in the upper parts of a shear wall.

Web reinforcement, consisting of horizontal bars, fully anchored at the extremities of the wall section, must be provided so that

$$A_v = \frac{v_s b_w s}{f_y} = \frac{(v_i - v_c) b_w s}{f_y} \quad (B-35)$$

These provisions should ensure that diagonal tension failure across the wall will never occur. To guard against diagonal compression failure, which may occur in flanged walls, that are over-reinforced for shear, codes^(8, 16) set an upper limit for the value of v_i . These values were based on tests with monotonic loading. Recent tests by the Portland Cement Association⁽¹¹⁾ and the University of Berkeley⁽¹⁸⁾ have demonstrated, however, that web crushing in the plastic hinge zone may occur after only a few cycles of reversed loading involving displacement ductilities of 4 or more. When the imposed ductilities were only 3 or less, the shear stresses stipulated by existing codes⁽¹⁶⁾ could be repeatedly attained. Web crushing may eventually lead to apparent sliding shear failure, as shown in figure 25. To prevent such failure the ideal shear strength of the wall should be such that

$$v_{i,max} \leq (0.3 \phi_o S + 0.16) \sqrt{f'_c} \leq 0.8 \sqrt{f'_c} \text{ (MPa)} \quad (B-36)$$

It is seen that for cantilever shear walls with $\phi_o = 1.39$ and a structural type factor of $S = 1.6$, in which limited

displacement ductility demand is expected, the design shear stress will attain the maximum value considered for all structures i.e. $0.8 \sqrt{f'_c}$ MPa. On the other hand for a coupled shear wall structure with $\phi_o = 1.39$ and $S = 0.8$, $v_{i,max} = 0.49 \sqrt{f'_c}$.

Control of sliding shear

It is likely that sliding in the plastic hinges of walls is better controlled by conventional reinforcement than it is in beams where sliding, resulting from high intensity reversed shear loading, can significantly affect the hysteretic response (see figure 4). The reasons for this are that most shear walls carry some axial compression due to gravity and this assists in closing cracks across which the tension steel yielded in the previous load cycle, and that the more uniformly distributed and embedded vertical bars across a potential sliding plane provide better dowel shear resistance.

Also, more evenly distributed vertical bars across the wall section provide better crack control. In beams several small cracks across the flexural reinforcement may merge into one or two large cracks across the web, thereby forming a potential plane of sliding. Because of the better crack control and the shear stress limitation imposed by Eq. (B-36), it does not appear to be necessary to provide diagonal steel across the potential sliding planes of the plastic hinge zone, as it has been suggested⁽⁸⁾ for beams. However, it is recommended that in low rise shear walls some of the shear should be resisted by diagonal bars, placed in the middle of the wall thickness, particularly when the minimum axial compression stress on such walls is less than $0.1 f'_c$ and the shear stress exceeds $0.4 \sqrt{f'_c}$. Suggested arrangements are shown in figure 26. Such bars should be included in the evaluation of the flexural resistance and may be included in the resistance to diagonal tension.

Construction joints represent potential weaknesses where sliding shear displacement can occur. Therefore it is recommended that the design for shear transfer across construction joints be based on the shear friction mechanism⁽²⁾. Accordingly where shear is resisted at a construction joint by friction between carefully roughened surfaces and by dowel action of the vertical reinforcement, the ratio of reinforcement that crosses at right angles to the construction joint should not be less than

$$\rho_{vf} = \left(V_{wall} - \frac{N_u}{A_g} \right) \frac{1}{f_y} > 0.0025 \quad (B-37)$$

where N_u is the minimum design compression force on the wall. For tension, N_u should be taken as negative. V_{wall} is obtained from Eq. (B-20) or Eq. (B-25).

Detailing of Coupling Beams

The ductility demand on coupling beams of coupled shear walls, such as examined in "Coupled Shear Walls", can be large.

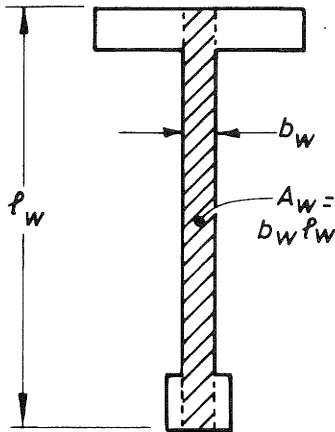

Fig. 29 - Effective Shear Area of a Flanged Wall Section.

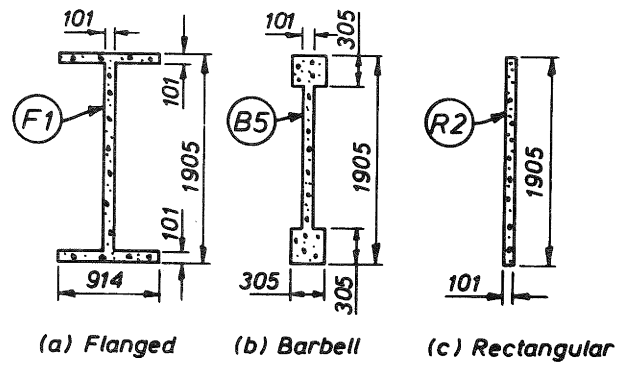

Fig. 30 - Nominal Cross Sectional Dimensions of the PCA Test Specimens (11).

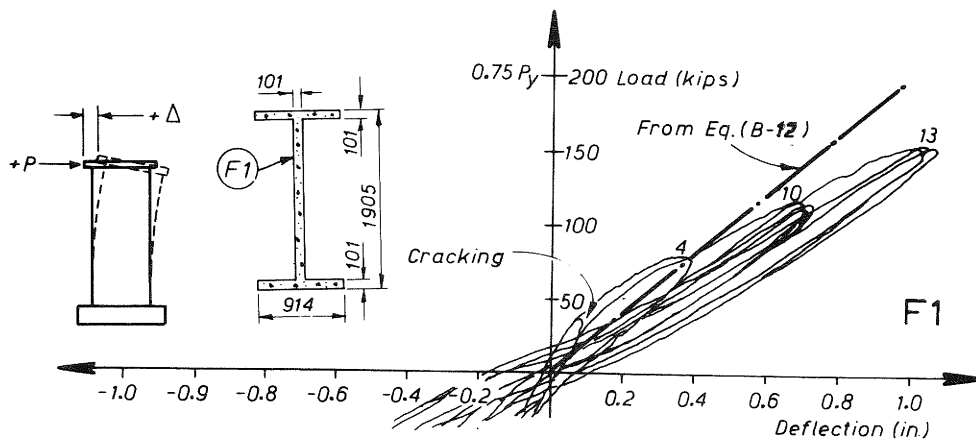

Fig. 31 - Continuous Load-Deflection Plot for Initial Cycles for the Flanged Wall Specimen F1.

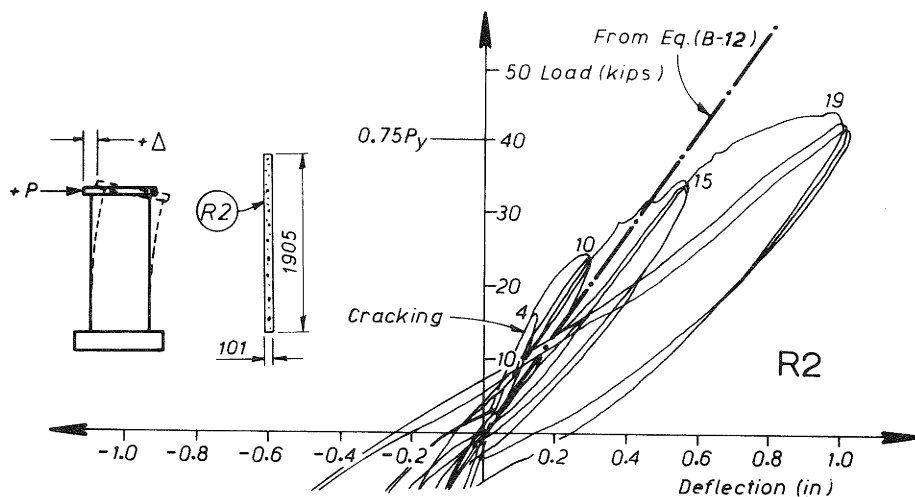

Fig. 32 - Continuous Load-Deflection Plot for Initial Cycles for the Rectangular Wall Specimen R2.

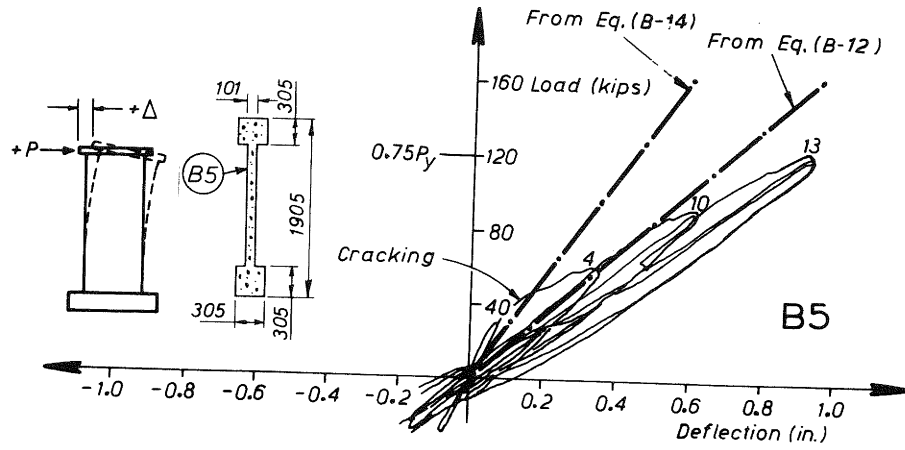

Fig. 33 - Continuous Load-Deflection Plot for the Initial Cycles for Specimen B5.

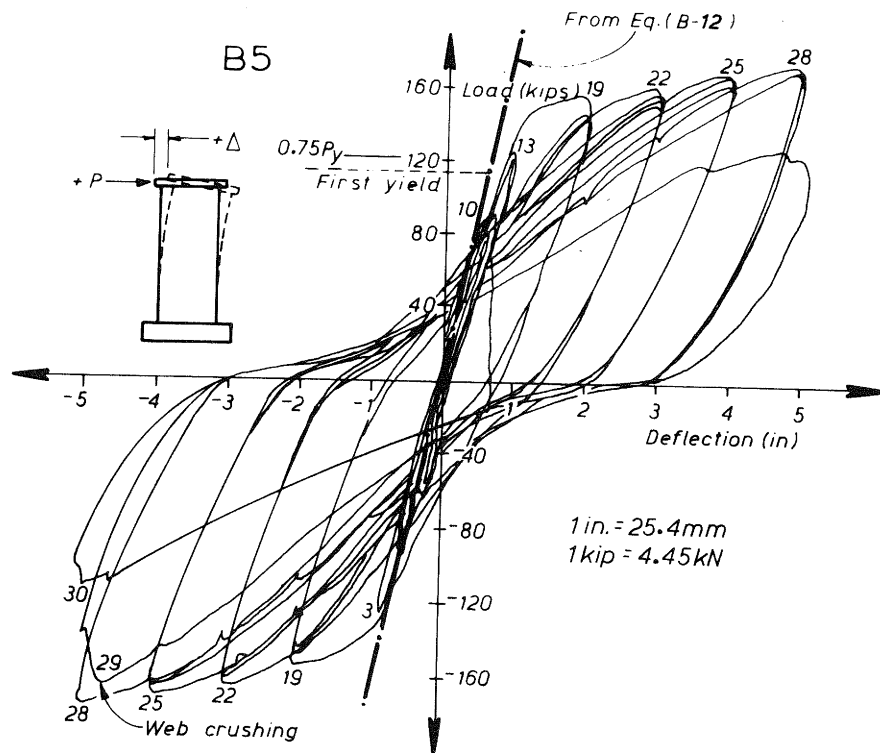

Fig. 34 - Continuous Load-Deflection Plot for all Cycles for Specimen B5

(See figure 7b). To preserve the energy dissipating properties of such beams, which are often relatively deep, diagonal reinforcement should be utilized⁽²⁾ to resist simultaneously both the moments and the shear. Diagonal bars in cages should be confined to ensure that buckling of diagonal bars cannot occur. For this purpose Eq. (B-30) and the rules listed in 'Confinement of longitudinal bars' should be followed. However neither the spacing of ties nor the pitch of rectangular spirals should exceed 100 mm.

When coupling beams are as slender as normal beams, which are used in ductile frames, distinct plastic hinges will form at the ends and these can be detailed as for beams. The danger of sliding shear failure and the inhibition of flexural ductility increases with increased depth to span ratio, h/ℓ , and with increased shear stresses. Therefore it is recommended that in coupling beams of shear walls the entire seismic design shear and flexure should be resisted by diagonal reinforcement in both directions unless the earthquake induced shear stress is less than

$$v_i = 0.1 \frac{\ell}{h} \sqrt{f'_c} \quad (\text{B-38})$$

It should be noted that this severe limitation is recommended because coupling beams can be subjected to much larger rotational ductility demands than spandrel beams of similar dimensions in frames. There is no limitation on the inclination of the diagonal bars.

Slab Coupling of Walls

When walls are interconnected by slabs only, as shown in figure 17c, the stiffness and strength of the coupling between the two walls becomes difficult to define. In the elastic range of displacement a considerable width of the slab will participate in load transfer. However, when inelastic deformations occur in the doorway, as illustrated in figure 27, a dramatic loss of stiffness can be expected⁽¹⁵⁾. Even when the flexural reinforcement is placed in a narrow band, with a width approximately equal to that of the doorway, and the band is confined by stirrup-ties enclosing the top and bottom slab bars in the band, it is difficult to control punching shear around the toes of the walls. From preliminary studies⁽¹⁵⁾ it appears that the hysteretic response of slab coupling is poor and that this system does not provide good energy dissipation with reversed inelastic cyclic loading. As figure 18 indicates, the contribution of slab coupling to the total moment of resistance is not likely to be significant. For this reason its contribution to seismic strength should be neglected in most cases.

When shallow beams, projecting below the slab, are provided across doorways, it must be expected that they will fail in shear, unless the very significant contribution of the slab reinforcement, placed parallel to the coupled walls, is

included in the evaluation of the flexural overcapacity of the relevant beam hinge, and thus in the evaluation of the imposed shear.

NOTATION:

- A = moment parameter used for coupled shear walls
- A_b = area of one bar, mm^2
- A_C^* = area of concrete core in the outer half of section which is subjected to compression strains, measured to outside of peripheral hoop legs, mm^2
- A_e = effective area of the cross section of a wall subjected to axial load
- A_g = gross area of section, mm^2
- A_g^* = gross area of the outer half of wall section which is subject to compression strains, mm^2
- A_{sh} = total effective area of hoop bars and supplementary cross ties in directions under consideration within spacing s_h , mm^2
- A_{te} = area of one leg of stirrup or stirrup tie, mm^2
- A_v = area of shear reinforcement within a distance s , mm^2
- A_w = effective web area of wall cross section, mm^2
- b = width of compression face of member or thickness of rectangular wall section
- b_w = web width or wall thickness
- c = computed distance of neutral axis from compressive edge of the wall section
- c_c = critical value of c
- d = distance from extreme compression fibre to centroid of tension steel
- e_x, e_y = eccentricity of centre of mass in x and y directions respectively
- E_c = modulus of elasticity of concrete, MPa
- f = form factor considered with shear deformation
- f'_c = specified compressive strength of concrete, MPa
- f_r = modulus of rupture of concrete, MPa
- f_y = specified yield strength of steel reinforcement, MPa
- f_{yh} = specified yield strength of hoop or supplementary cross tie steel, MPa
- G_c = modulus of rigidity of concrete, MPa
- h = overall thickness of member or depth of beam, mm

h_w	= overall height of wall of horizontal length ℓ_w , mm	P_e	= maximum design axial load due to gravity and seismic loading acting on the member during an earthquake, N
h''	= dimension of concrete core of section measured perpendicular to the direction of the hoop bars, mm	P_{eq}	= axial load on member due to design earthquake loading only
I	= importance factor	P_{LR}	= axial load on member due to reduced live load
I_{cr}	= moment of inertia of cracked section transformed to concrete	P_{eq}^o	= maximum axial load on member due to earthquake only at the development of flexural overcapacity
I_e	= effective moment of inertia for computation of flexural and shear deflections	P_1^o, P_2^o	= design axial tension and compression force acting on wall at the development of the flexural overstrength capacity of the structure
I_g	= moment of inertia of gross concrete section about centroidal axis	Q_i^o	= shear overcapacity of a coupling beam
I_w	= equivalent moment of inertia of wall section neglecting the reinforcement for computing total deflections	s	= spacing of stirrups, mm
ℓ	= distance between axes of shear walls	s_h	= vertical spacing of horizontal reinforcement, mm
ℓ_n	= length of clear span or distance, measured face to face of support	s_v	= horizontal spacing of vertical reinforcement along length of wall, mm
ℓ_w	= horizontal length of wall	S	= structural type factor
M_a	= maximum moment in member at stage for which deflection is being computed	T	= tension force or period of vibration, seconds
M_{cr}	= cracking moment	v_c	= nominal permissible shear stress carried by concrete, MPa
M_{code}	= moment induced by code specified static loading	v_i	= ideal shear stress, MPa
M_i	= ideal flexural strength of wall section	v_s	= nominal shear stress allocated to resistance of web reinforcement, MPa
M_o	= overturning moment at the base of a shear wall structure due to code load	V_{code}	= shear demand derived from code loading
M^o	= moment developed at flexural overcapacity of member	V_i	= ideal shear capacity of wall
M_1, M_2	= moments due to code loading developed at the base of the wall concurrently with earthquake induced axial tension or compression respectively	V_{wall}	= design shear force for a wall at the development of the flexural overcapacity of the structure
M_1^o, M_2^o	= flexural overcapacity developed in the tension and compression wall respectively	V^o	= shear force developed at flexural overcapacity
M_1', M_2'	= design moments at the base after moment redistribution in the tension and compression walls respectively	y_t	= distance from centroidal axis of gross section, neglecting the reinforcement, to the extreme fibre in tension
n	= number of floors above the section of wall being considered	Z	= modifier of structural type factor
N	= number of storeys in a shear wall structure	Δ_f	= wall deflection due to anchorage deformations only
N_u	= design axial compression load normal to cross section occurring simultaneously with the design shear force, N	Δ_m	= wall deflection due to flexural deformations only
P_D	= axial load on member due to dead load only	Δ_u	= deflection at top of shear wall at ultimate state
		Δ_v	= wall deflection due to shear deformations only
		Δ_y	= deflection at top of shear wall at first yield

ϕ	= strength reduction factor
ϕ_u	= curvature at maximum displacement ductility
ϕ_y	= curvature at first yield
ϕ_o	= overstrength factor
ϵ_c	= specified compression strain at extreme concrete fibre, 0.003
ϵ_{ce}	= compression strain at extreme concrete fibre at first yield of tension steel
ϵ_u	= compression strain at extreme concrete fibre at development of a maximum curvature
ϵ_y	= yield strain of reinforcement
μ_Δ	= displacement ductility factor
μ_ϕ	= curvature ductility factor
ω_v	= dynamic shear magnification factor
ρ_ℓ	= ratio of vertical tension reinforcement in wall spaced at s_v
ρ_{vf}	= ratio of reinforcement crossing unit area of construction joint

REFERENCES:

- NZS 4203 : 1976 "Code of Practice for General Structural Design and Design Loadings for Buildings", Standards Association of New Zealand, 80 pp.
- Park, R. and Paulay, T., "Reinforced Concrete Structures", John Wiley and Sons, New York, 1975, 769 pp.
- Taylor, R.G., "Introduction to and Aims in the Design of Earthquake Resisting Shear Wall Structures", Section A of the Shear Wall Study Group of the New Zealand National Society for Earthquake Engineering, The Bulletin of the New Zealand National Society for Earthquake Engineering, Vol. 13, No. 2, 1980.
- Robinson, L.M., "Shear Walls of Limited Ductility", Section C of the Shear Wall Study Group of the New Zealand National Society for Earthquake Engineering, The Bulletin of the New Zealand National Society for Earthquake Engineering, Vol.13, No. 2, 1980
- Binney, J. and Paulay, T., "Foundations for Shear Wall Structures", Section F of the Shear Wall Study Group of the New Zealand National Society for Earthquake Engineering, The Bulletin of the New Zealand National Society for Earthquake Engineering, Vol. 13, No. 2, 1980.
- Powell, G.H., "DRAIN - 2D Users Guide", Report EERC 73-22, Earthquake Engineering Research Centre, University of California, Berkeley, April 1973.
- "ICES-STRUDL-II", Engineering Users' Manual, Vol. 1, 1967, Vol. 2, 1969, Vol. 3, 1970, Massachusetts Institute of Technology.
- DZ 3101 : Part 1 and Part 2, Draft New Zealand Standard Code of Practice for the Design of Concrete Structures, Standards Association of New Zealand, 1978.
- Sharpe, R.D., "The Seismic Response of Inelastic Structures", Ph.D. thesis, University of Canterbury, Christchurch, New Zealand, Nov. 1974, 126 pp.
- Paulay, T. and Spurr, D.D., "Simulated Seismic Loading on Reinforced Concrete Frame - Shear Wall Structures", 6th World Conference on Earthquake Engineering, New Delhi, 1977, Preprints 3, pp. 221-226.
- Oesterle, R.G., Fiorato, A.E., Johal, L.S., Carpenter, J.E., Russell, H.G. and Corley, W.G., "Earthquake Resistant Structural Walls - Tests of Isolated Walls," Report to National Science Foundation, Portland Cement Association, Nov. 1976, 44 pp. (Appendix A, 38 pp. Appendix B, 233 pp.)
- Blakeley, R.W.G., Cooney, R.C. and Megget, L.M., "Seismic Shear Loading at Flexural Capacity in Cantilever Wall Structures", Bulletin of the New Zealand National Society for Earthquake Engineering, Vol. 8, No. 4, December 1975, pp. 278-290.
- Fintel, M., Derecho, A.T., Freskakis, G.N., Fugelso, L.E. and Gosh, S.K., "Structural Walls in Earthquake Resistant Structures", Progress Report on the National Science Foundation, (RANN) Portland Cement Association, Skokie, Aug. 1975, 261 pp.
- Paulay, T. and Uzumeri, S.M., "A Critical Review of the Seismic Design Provisions for Ductile Shear Walls of the Canadian Code and Comments", Canadian Journal of Civil Engineering, Vol. 2, Dec. 1975, pp. 592-601.
- Taylor, R.G., "The Nonlinear Seismic Response of Tall Shear Wall Structures", Ph.D. thesis, Research Report 77/12, Department of Civil Engineering, University of Canterbury, Christchurch, New Zealand, 1977, 234 pp.
- ACI Committee 318, "Building Code Requirements for Reinforced Concrete, (ACI 318-77)", American Concrete Institute, Detroit, 1977, 102 pp.
- Park, R., "Columns Subjected to Flexure and Axial Load", Bulletin of the New Zealand National Society for Earthquake Engineering, Vol. 10, No. 2, June 1977, pp 95-105.
- Bertero, V.V., Popov, E.P., Wang, T.Y. and Vallenias, J., "Seismic Design Implications of Hysteretic Behaviour of Reinforced Concrete Structural Walls", 6th World Conference on

Earthquake Engineering, New Delhi, 1977, Preprints 5, pp. 159-165.

19. Clough, R.W. and Penzien, J., "Dynamics of Structures", Chapter 27, Mcgraw Hill, 1975, 634 pp.

$$I_e = \left(\frac{M_{cr}}{M_a} \right)^3 I_g + \left[1 - \left(\frac{M_{cr}}{M_a} \right)^3 \right] I_{cr} \quad (B-14)$$

The moment assumed to cause cracking is from first principles⁽²⁾

$$M_{cr} = \frac{f_r I_g}{y_t} \quad (B-15)$$

It is seen that the relationship between the second moment of area and the moments are such that $I_g \geq I_e \geq I_{cr}$ where $1 \geq (M_{cr}/M_a) \geq 0$.

For beams and columns of normal proportions and reinforcement contents it is found that usually $0.4 < I_{cr}/I_g < 0.6$, and hence the equivalent moment of inertia is such that $0.5 < I_e/I_g < 0.7$. Consequently in the elastic analysis of frames customarily the "gross moment of inertia", I_g of members is used, and this is reduced by 30 to 50% to allow for the effects of cracking.

In structural walls usually considerably less flexural reinforcement is being used than in beams of ductile earthquake resisting frames. The flexural tension steel content, $\rho = A_s/bd$, to be considered in the evaluation of flanged transformed wall sections can be as small as 0.05%. Consequently in such walls the "transformed moment of inertia", I_{cr} will be a smaller fraction of the "gross moment of inertia", I_g . Cracking has thus a more profound effect on the stiffness of normal walls than on that of beams.

The flexural deformation, shown in figure 28d can therefore be obtained thus

$$\Delta_m = \frac{Ph_w^3}{3E_c I_e} \quad (I-2)$$

Anchorage Deformations

The analytical model commonly used is a cantilever. This is fully fixed against rotations at its base. (figure 28a). Under lateral load the vertical wall reinforcement is at its highest stress at the base. Consequently tensile strains along the flexural bars will only gradually decay in the foundation structure. The elongation of the vertical bars within the foundation structure and the slip due to high local bond stresses along the development length will result in an apparent "pull out" of such bars at the base of the wall. This can significantly increase the wall deflection, as shown in figure 28e. Based on the relative magnitudes of observed "pull out" deformations, it is suggested that its magnitude be estimated as

$$\Delta_f = 0.2 \Delta_m \quad (I-3)$$

Shear Deformations

It is well known that shear deformations

APPENDIX I

THE ESTIMATION OF DEFLECTIONS OF CRACKED REINFORCED CONCRETE CANTILEVER WALLS

Assumptions

Deflection estimates generally used in seismic design should reflect the behaviour of the structure after the development of extensive cracking at a load level which, as yet, does not result in inelastic deformations. Therefore for the purpose of the derivations that follow, wall behaviour at 75% of the theoretical yield load will be considered. The yield load is that which causes the main part of the flexural reinforcement, placed in boundary regions of walls, such as flanges, to yield. If for example the main flexural reinforcement in a wall section consists of seven layers of D28 bars, the yield load is that attained at the onset of yielding in the innermost (i.e. seventh layer of these D28 bars). This load will be close to the ideal flexural capacity.

In order to define the stiffness of any elastic member with given boundary conditions, a certain unit deformation must be related to a certain load pattern. For the purpose of this study the structure and the load on it are those shown in figure 28a and figure 28b, and the deformation to be determined is the lateral deflection at roof level, Δ , as shown in figure 28c.

The symbols used in the subsequent derivation are fully defined in the text or the list of symbols.

Flexural Deformations

The flexural deformations, being dominant, are normally the only ones that are considered in the design of flexural members. Accordingly the roof deflection for a homogeneous elastic cantilever wall of figure 28a is

$$\Delta = \frac{Ph_w^3}{3E_c I_g} \quad (I-1)$$

The most appropriate approach to the estimation of cracking is to allow for a loss of effective resisting area in the cross section. The effective moment of inertia of the section, I_e , will be between that based on the uncracked section, I_g , and that obtained from the fully cracked section in which the steel area is transformed to concrete area, I_{cr} . An interpolation for I_e between the above limits has been developed by Branson and it has been adopted by the American Concrete Institute⁽¹⁶⁾. Its background is examined elsewhere^(2, 8). This is

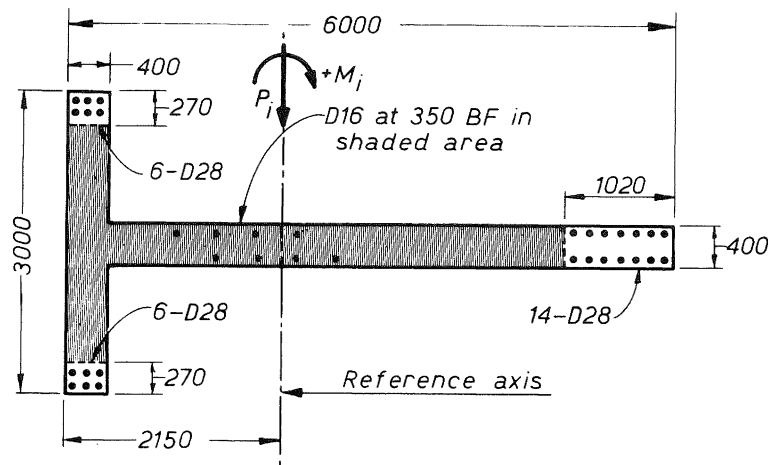

Fig. 35 - Sectional Properties of an Example Shear Wall Section.

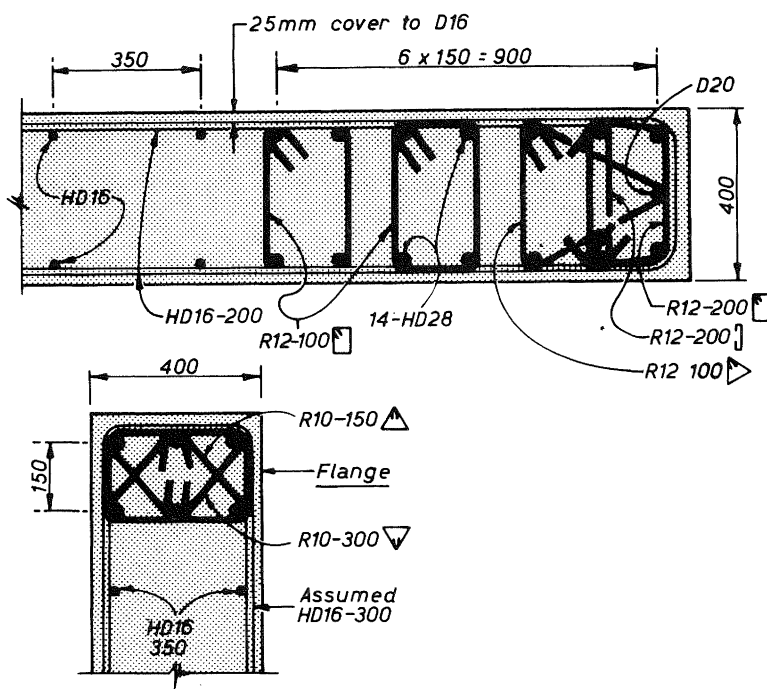

Fig. 36 - Arrangement of Transverse Reinforcement in the Critical Regions of the Example Shear Wall Section.

in slender flexural members are negligibly small in comparison with those due to flexure. Walls, however, may belong to the family of "deep beams", in which shear deformations are likely to be significant. Therefore shear deformations should be considered.

The shear deflection of a homogeneous elastic wall at roof level, shown in figure 28f, is known to be

$$\Delta_v = \frac{fPh_w}{G_c A_w} \quad (I-4)$$

The area of the wall, effective in shear, A_w , is defined in figure 29. It will be assumed that $A_w = b_w \ell_w$ for the common type of walls used.

It has been found that in members in which diagonal cracks have developed as a result of shear stresses, the relative contribution of shear deformations is considerably larger than what Eq. (I-4) would predict. It will be appreciated that after the development of diagonal cracking a new form of shear transfer begins to operate i.e. the truss mechanism. In this new mechanism the web reinforcement (stirrups) contributes to large shear strains. It has been shown⁽²⁾ that the shear stiffness of diagonally cracked beams is only 10-30% of that of uncracked beams, depending on the contribution of web reinforcement.

The estimation of shear deformation in a shear wall is complicated by the fact that the shear force in a real wall will decrease from a minimum at the top of the wall to a maximum at the base. Moreover, in the lower portions of the wall more extensive flexural and shear cracking will occur, and it can be expected that in these more heavily cracked zones the shear deformations will be larger. Taking these considerations into account it is suggested that the contributions of shear deformations along the height of a cantilever wall be estimated from the following simple expression:

$$\Delta_v = \frac{1.2 Ph_w}{0.4 E_c 0.3 A_w} = \frac{10 Ph_w}{E_c A_w} \quad (I-5)$$

Combined Deformations

It is seen from figure 28 that the roof deflection of the cracked cantilever wall due to flexural, anchorage pull-out and shear deformations is $\Delta = \Delta_m + \Delta_f + \Delta_v$. Substituting from Eqs. (I-2), (I-3) and (I-5) we obtain

$$\Delta = \frac{Ph_w^3}{3E_c I_e} + \frac{0.2Ph_w^3}{3E_c I_e} + \frac{10Ph_w}{E_c A_w} \quad (I-6)$$

It is convenient to express the deflection in terms of flexural deformations and an equivalent wall moment of inertia, I_w , so that

$$\Delta = \frac{Ph_w^3}{3E_c I_w} \quad (I-7)$$

By equating the above two equations the equivalent wall moment of inertia, I_w , is obtained thus

$$I_w = \frac{I_e}{1.2 + F} \quad (B-12)$$

where value of I_e is given by Eq. (B-14) and

$$F = \frac{30 I_e}{h_w^2 b_w \ell_w} \quad (B-13)$$

A Comparison with Experiments

Recently the Portland Cement Association in Skokie (US) carried out extensive testing with cantilever shear walls⁽¹¹⁾. Some observed results of this programme are compared with values obtained from Eq. (B-12) and Eq. (B-14). All the walls reported have the same aspect ratio of $h_w/\ell_w = 2.4$. This is in the range where shear deformations are likely to be significant.

The basic dimensions of the cross sections used for the 4752 mm high wall specimens are shown in figure 30. A comparison of predicted deflections with observed ones was made for all seven specimens reported. However, representative results for only three of the cases are presented here.

Figure 31 shows the initial cycles of the load displacement relationship for the flanged wall specimen (figure 30), when the load did not exceed approximately 60% of the yield load P_y . The straight line shows the idealized^y relationship that would have resulted from Eq. (B-12).

A similar relationship is shown in figure 32 for a wall with a rectangular cross section. In the response shown the maximum load reached approximately 83% of the yield load, P_y .

Finally a comparison is made for a wall with a rectangular boundary element (barbell), B-5, in figure 33. Here Eqs. (B-12) and (B-14) are compared. It is seen that Eq. (B-14) generally recommended⁽⁸⁾ for the prediction of beam deflection, overestimates the wall stiffness. The differences in deflections, as predicted by the two equations, result from the considerations of shear and anchorage deformations, which have been incorporated into Eq. (B-12). The full response, including the inelastic cycles, of this wall specimen, is shown in figure 34.

With respect to the PCA experiments used here, it may be said that the suggested deflection estimate procedure should be acceptable for design purposes.

APPENDIX II

DESIGN OF A CANTILEVER SHEAR WALL

Design Requirements and Properties

Preliminary design has indicated that one of several symmetrically arranged canti-

lever shear walls of a 11 storey Class III building, resisting the required seismic loading, may be dimensioned and reinforced at ground floor level as shown in figure 35. In this study seismic actions in the longitudinal direction of the wall sections are considered only. The first storey is 3.50 m high and the upper 10 storeys are 3.25 m each.

The strength properties to be used are as follows:

Concrete	$f'_c = 25\text{MPa}$
Vertical wall reinforcement	$f_y = 380\text{MPa}$
Horizontal wall shear reinforcement	$f_y = 380\text{MPa}$
Horizontal hoops and ties	$f_y = 275\text{MPa}$

The total loading at ground floor level from all the tributary areas of the upper floors is as follows:

Dead load	7000 kN
Reduced live load	3000 kN

The centre of the lateral static load, used in the preliminary design, was located at 23 m above ground floor. At ground level the wall is assumed to be fully fixed against rotations.

Minimum requirements with respect to

- i) Section "Stability" i.e. $\lambda_n/b < 3500/400 = 8.75 < 10$
- ii) Section "Longitudinal Wall Reinforcement" i.e. $\rho_{\ell, \min} = 0.7/380 < 2 \times 201/(400 \times 350) = 0.004$

and

- iii) Bars spacing requirements are all satisfied

Flexural Capacities

The flexural capacities are to be evaluated for each direction of loading. The maximum axial compression to be considered for the evaluation of the available ideal flexural strength is from(1)

$$U_{\text{ideal}} = (D + L_R)/\phi = (7000 + 3000)/0.9 = 11,100 \text{ kN}$$

Loading causing compression in the flange

$$P_i = 11,100 \text{ kN} \quad M_i = ?$$

Using a trial and error process, the neutral axis depth will be estimated so that the internal compression forces less the tensile forces will give a compression resultant of approximately 11 MN. Then the moment about the reference axis (the centroid of the gross concrete section) will be computed.

Assume first $c = 0.05 \times 6000 = 300 \text{ mm}$

The D16 bars provide $(2 \times 201)380/(0.35 \times 10^6) = 0.44 \text{ MN}$ force per meter wall length.

Ignore contribution of reinforcement in the flange and the reduction of steel flexural contribution in the elastic core of the section then:

Compression	$C_c = (0.85 \times 300)3000 \times (0.85 \times 25)/10^6 = 16.3\text{MN}$
Tension	$T_{28} = 14 \times 615 \times 380/10^6 = 3.27$
	$T_{16} = (6.0 - 0.4 - 1.02)/0.44 = 2.01$
	Total tension $T = 5.28 = 5.3\text{MN}$

$$\begin{aligned} \text{Therefore } C_c - T &= P_i = 11.0\text{MN} \\ M_i &= 16.3(2.15 - 0.5 \times 0.85 \times 0.3) = 33.0\text{MNm} \\ &3.27(6.00 - 2.15 - 0.5 \times 1.02) = 10.9\text{MNm} \\ &2.01(0.5 \times 4.58 + 0.4 - 2.15) = 1.1\text{MNm} \end{aligned}$$

No new trial for c is required. Therefore $M_i = 45.0\text{MNm}$

Loading causing tension in the flange

$$P_i = 11.1 \text{ MN} \quad M_i = ?$$

Assume first $c = 0.35 \times 6000 = 2100 \text{ mm}$

Compression	$C_c = (0.85 \times 2100)400(0.85 \times 25)/10^6 = 15.2\text{MN}$
	$C_{28} = 14 \times 615 \times 380/10^6 = 3.3\text{MN}$
	$C_{16} = \text{neglect} = -$
	Total compression $C = 18.5\text{MN}$
Tension	$T_{28} = (6 \times 615)380/10^6 = 1.4\text{MN}$
in the flange	$T_{16} = (3.0 - 2 \times 0.27)0.44 = 1.1\text{MN}$
in the web	$T_{16} = (6.0 - 0.4 - 2.1)0.44 = 1.5\text{MN}$
	Total tension $T = 4.0\text{MN}$

$$\text{Net compression } P_i = 11.1 < 14.5\text{MN}$$

Reduce a by $\Delta a = (14.5 - 11.1)/10^6/(0.85 \times 25 \times 400) = \text{say } 370 \text{ mm}$

Hence $c = 2100 - 370/0.85 = 1664 \text{ mm}$

by proportion

	$C_c = 1664 \times 15.2/2100 = 12.0\text{MN}$
	$C_{28} = \text{as before} = 3.3\text{MN}$
	$C_{16} = \text{as before} = -$
	Total compression $C = 15.3\text{MN}$
	$T_{28} = \text{as before} = 1.4\text{MN}$
in the flange	$T_{16} = \text{as before} = 1.1\text{MN}$
in the web	$T_{16} = (6.0 - 0.4 - 1.66)0.44 = 1.7\text{MN}$
	Total tension $T = 4.2\text{MN}$
	$P_i = 11.1 = 11.1\text{MN}$

$$M_i = 12.0(6.0-2.15-0.85 \times 1.66 \times 0.5) = 37.7 \text{ MNm}$$

$$3.3(6.0-2.15-0.5 \times 1.02) = 11.0 \text{ MNm}$$

$$(1.4+1.1)(2.15-0.5 \times 0.4) = 4.9 \text{ MNm}$$

$$1.7\{-(6.0-0.4-1.66)0.5+2.15-0.4\} = 0.4 \text{ MNm}$$

Hence moment of resistance
is $M_i = 53.2 \text{ MNm}$

Design for Shear

As the ideal moment capacity for the most adverse load combination is 53.2MN, the code required shear is close to $0.9 \times 53.2 / 23 = 2.08 \text{ MN}$.

For a 11 storey building the dynamic shear magnification from Table B-I is $\omega_v = 1.7$. With a flexural overstrength of 125% of ideal strength, the design shear force for the wall is obtained from Eq. (B-18).

$$V_{\text{wall}} = 1.7 \times 1.25 \times 2.08 = 4.42 \text{ MN}$$

Hence from Eq. (B-32)

$$v_i = 4.42 \times 10^6 / (400 \times 0.8 \times 6000) = 2.30 \text{ MPa}$$

From Eq. (B-36) the maximum allowable shear stress is

$$v_{i,\text{max}} = (0.3 \times 1.39 \times 1.0 + 0.16) / \sqrt{25} = 2.89 > 2.30 \text{ MPa}$$

$$N_u / A_g = 11.1 \times 10^6 / \{6000 \times 400 + (3000 - 400) 400\} = 3.23 \text{ MPa}$$

From Eq. (B-34)

$$v_c = 0.25(1 + 25/25) \sqrt{3.23 - 25/10} = 0.43 \text{ MPa}$$

From Eq. (B-33)

$$v_s = v_i - v_c = 2.30 - 0.43 = 1.87 \text{ MPa}$$

From Eq. (B-35)

$$A_v = 1.87 \times 400 \times s / 380 = 1.97s$$

Assume two legs of HD16 bars, $A_v = 402 \text{ mm}^2$

$$s = 402 / 1.97 = 204 \approx 200 \text{ mm}$$

Use HD16 at 200 mm crs for horizontal shear (stirrup) reinforcement

Confinement

It is evident that no confinement is required when the flange is in compression as the section is extremely ductile with $c/l_w = 0.05$. However, when the flange is in tension the stem of the section will need to be confined. For this it was found in "Loading causing tension in the flanges", that $c = 1664 \text{ mm}$.

From Eq. (B-26) with $\phi_o = 1.4$

$$c_c = 0.10 \times 1.4 \times 1.0 \times 6000 = 840 < 1664$$

Hence provide confinement over a length of $0.5 \times 1664 = 832 \text{ mm}$

For Eqs. (B-28) and (B-29) to be used take the following values

$$h'' = 832 - 41 + 0.5 \times 12 = 797 \approx 800,$$

$$A_g^* = 400 \times 832 = 333000 \text{ mm}^2, \text{ Assume R12 ties,}$$

Assume cover to HD stirrups = 25 mm and to main bars 41 mm, hence

$$A_c^* = (400 - 2 \times 41 + 2 \times 12)(832 - 41 + 12) = 275000 \text{ mm}^2$$

$$(A_g^* / A_c^* - 1) = (333 / 275 - 1) = 0.21$$

$0.3 \times 0.21 = 0.063 < 0.12$ hence Eq. (B-29) governs

From Eq. (B-29)

$$A_{sh} = 0.12 s_h 800 \times (25/275)(0.5 + 0.9 \times 1664/6000) = 6.54 s_h$$

With 6 R12 legs over 800 mm length

$$s_h = 6 \times 113 / 6.54 = 104 \text{ mm}$$

From the spacing requirements stated in "Confining reinforcement"

$$s_{h,\text{max}} = 6 \times 28 = 168 \text{ or } 400/3 = 133 \text{ or } 150 \text{ mm}$$

Hence use R12 hoops and ties at 100 mm cr^s and for practical reason confine all 14 HD28 bars.

For the confinement in the longitudinal direction $h'' = 400 - 2 \times 41 + 12 = 330 \text{ mm}$

As the distance between the 2 HD28 bars is more than 200 mm, it will be necessary to place in the confined region an intermediate (nominal) bar in between them. A D20 bar will enable another tie to be placed over the 400 mm width of the section. Hence by proportion from the above derivation of A_{sh} and $s_h = 100$

$$A_{sh} = (330/800) 5.90 \times 100 = 243 \text{ mm}^2$$

R10 legs could be used, but for the sake of uniformity R12 ties will be provided as shown in figure 36.

To confine the HD28 bars against buckling at the ends of the flange, ties are required in accordance with 'Confinement of longitudinal bars' and Eq. (B-30)

From Eq. (B-31)

$$\rho_g = 3 \times 615 / 400 \times 150 = 0.0308 > 0.0075$$

Hence

$$A_{te} = \frac{615}{16} \frac{380}{275} \frac{s_h}{100} = 0.53 s_h$$

The max^m spacing is $6 \times 28 = 168 \text{ mm}$

R10 ties may be used, thus

$$s_h = 78.5 / 0.53 = 148 \text{ mm}$$

Use R10 ties at 150 mm cr^s as shown in figure 36

The confining reinforcement as computed should extend, in accordance with figure 15, to a height of $l_w = 6000 \text{ mm}$, i.e. up to the 2nd floor of this structure.

Note that a more rigorous analysis, using Eq. (B-27) would have given the critical value for the neutral axis depth as follows:

With $S = 1.0$, $l_w = 6000$ and $h_w =$
 $3.5 + 10 \times 3.25 = 36$ m

$$c_c = \frac{8.6 \times 1.4 \times 1 \times 6000}{(4 - 0.7 \times 1)(17 + 36/6)} = 952 \text{ mm} > 840 < 1664$$

Hence confinement is to be provided as computed above.